

# TIE PLATE

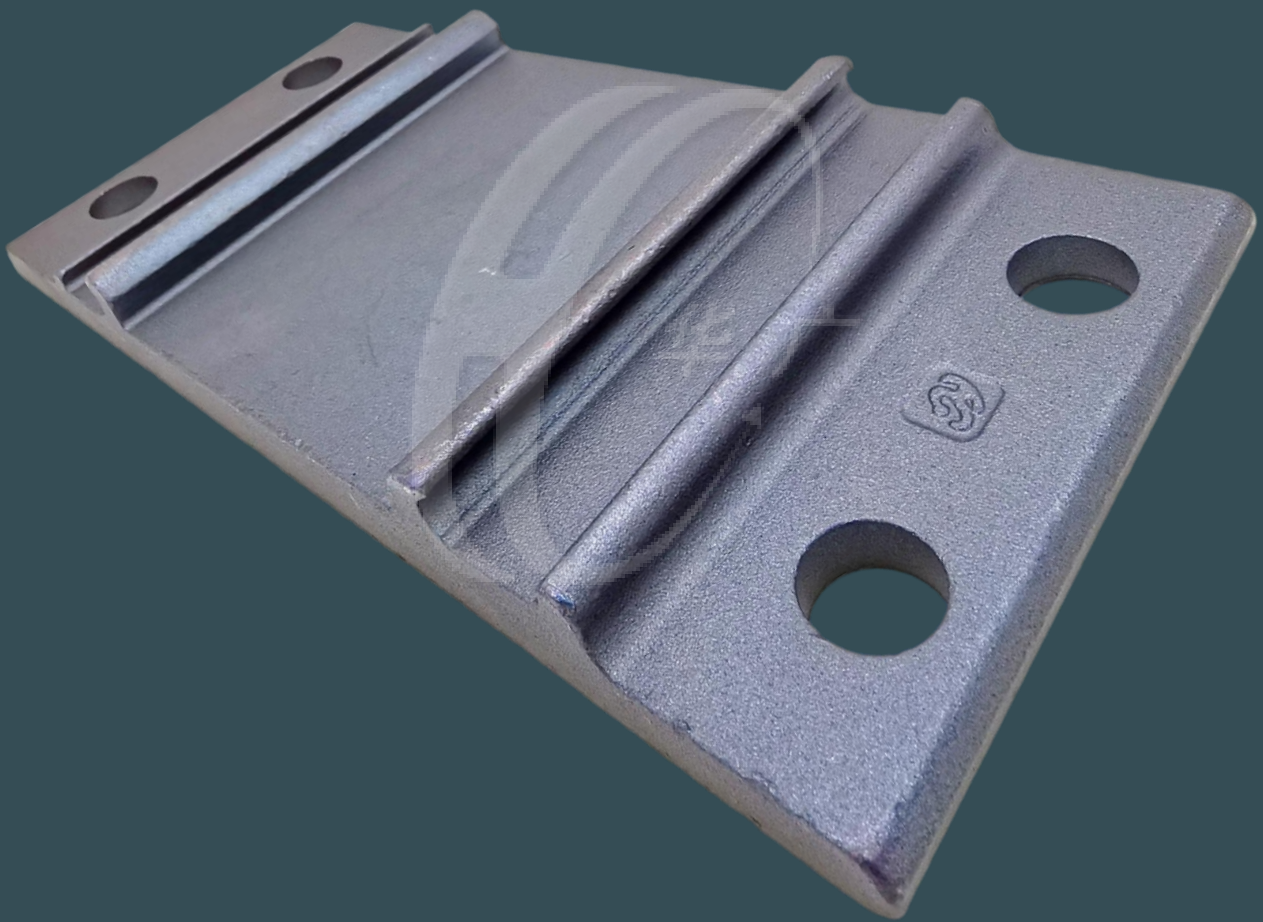

Huaguang Seiko OEM/ODM forged tie plates are designed and manufactured for meeting most of the specific and technical requirements in diverse countries' needs.





**Huaguang Seiko**

*Railroad Tie Plate OEM/ODM*

# PRODUCT CATALOGUE

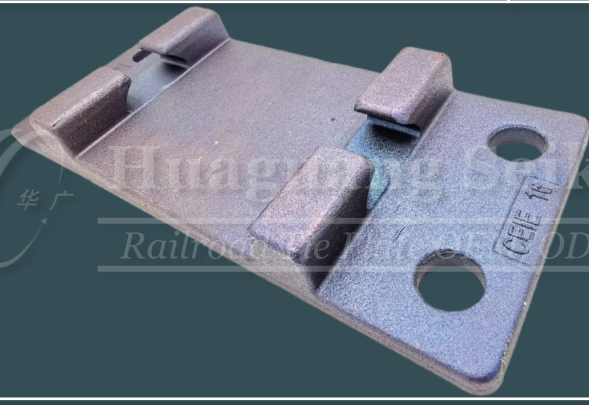
## TIE PLATE

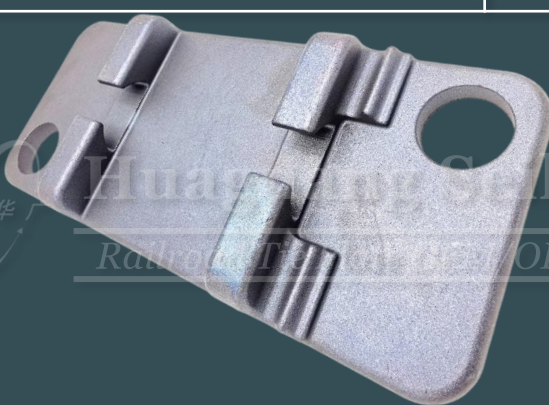
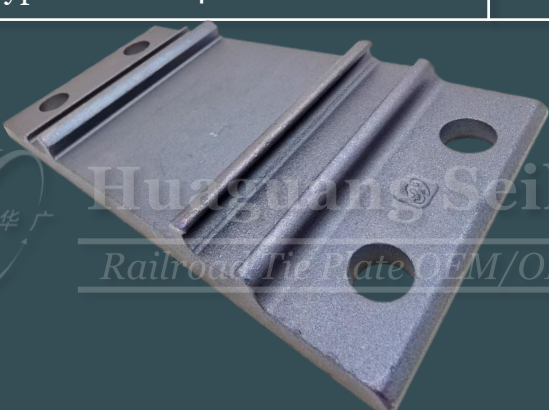
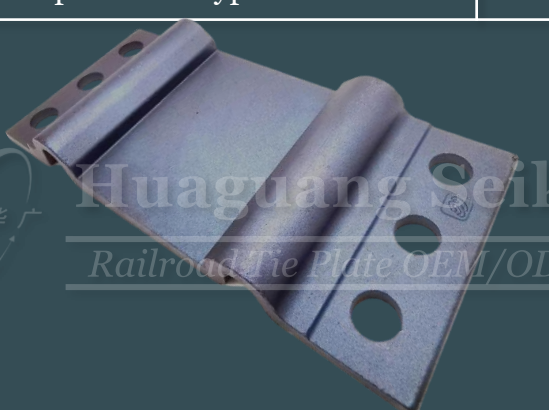
1. European Standard Railroad Type: S-45 / 49E1 / 54E2	Page.5	2. European Standard Railroad Type: 60UNI	Page.7
			
3. European High-speed Railroad Type: EHR-RP4R	Page.9	4. European High-speed Railroad Type: EHR-HB2R	Page.11
			
5. European High-speed Railroad Type: EHR-FS4R	Page.13	6. North American Metropolitan Transportation Type: NAMT-6R	Page.15
			

7. North American Metropolitan Transportation Type: NAMT-4R

Page.17

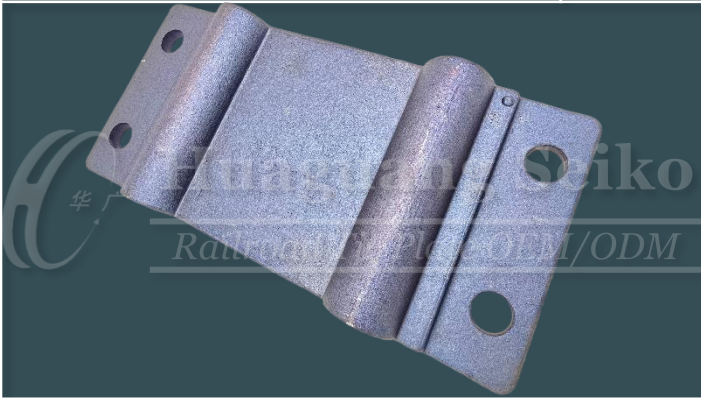

8. North American Standard Railway Type: NASR-8S

Page.19

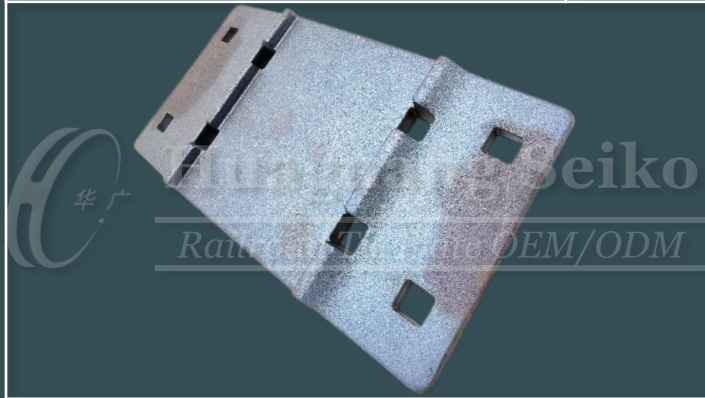

9. South American Standard Subway Type: SASS-4R

Page.21

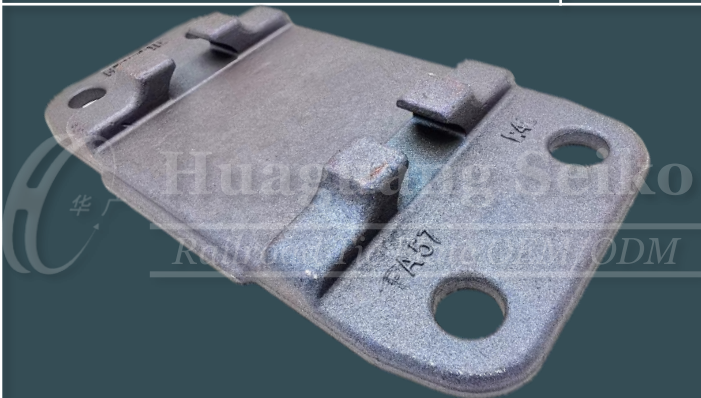

10. Japanese Bullet Train (Shinkansen) Type: JBT-2O

Page.23

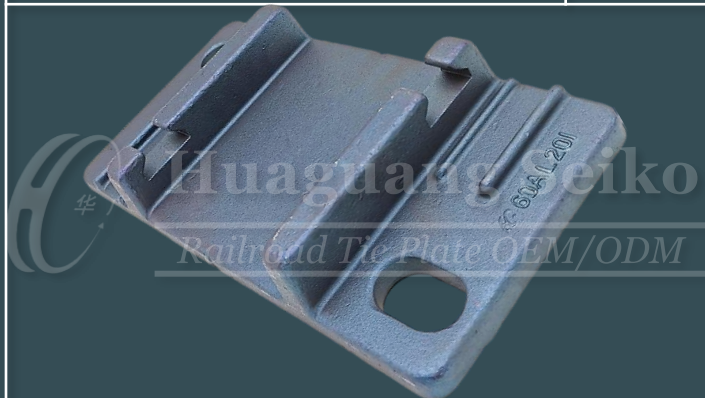

11. Japanese Bullet Train (Shinkansen) Type: JBT-4O

Page.25



12. Chinese High-speed Railway Type: CHR-2O

Page.27



13. Chinese High-speed Railway Type: CHR-2R Page.29

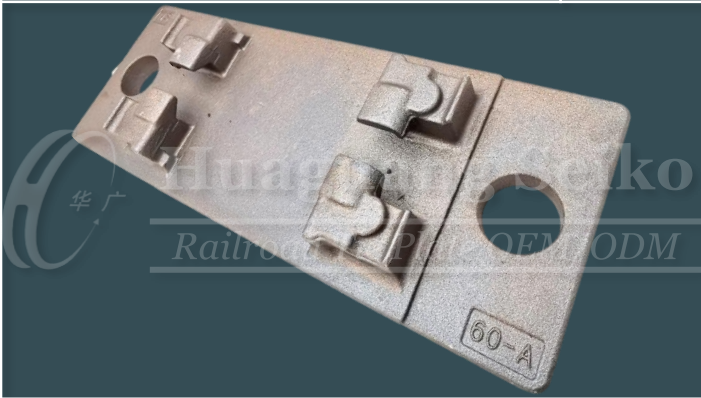

14. Chinese Special Subway Type: CST-4R Page.31



15. Middle Eastern Standard Railway Type: MESR-4R Page.33

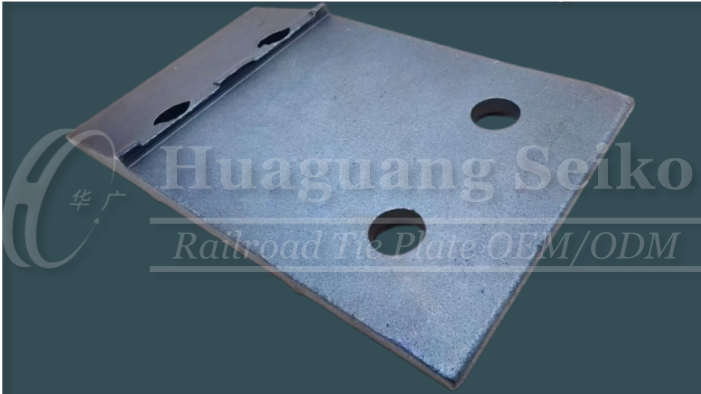

16. ASEAN Standard Subway Type: ASS-2R Page.35



17. ASEAN Standard Subway Type: ASS-4R Page.37

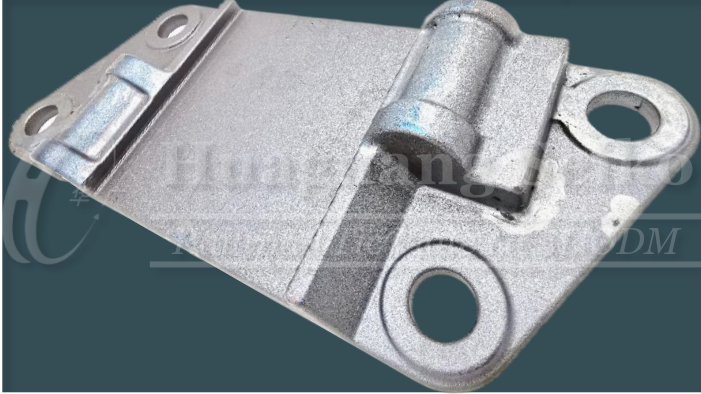

18. ASEAN Standard Subway Type: ASR-2O Page.39



19. ASEAN Special Railway Type:  
ASR-4R

Page.41



20. Oceanian High-speed Railway  
Type: OHR-4R

Page.43



21. Oceanian High-speed Railway  
Type: OHR-4O

Page.45

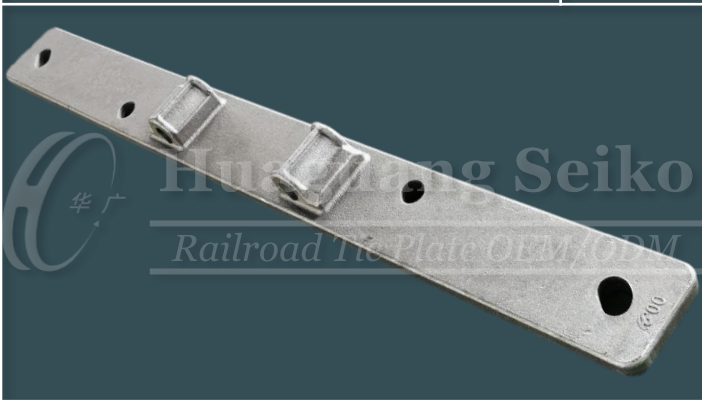

22. Rail Anchor Standard Type

Page.47



23. Fishplate Standard Type

Page.49



24. Fishplate Special Type

Page.51



# 1. European Standard Railroad Type: S-45 / 49E1 / 54E2



## QUOTATION<sup>(1)</sup>

Material Type <sup>(2)</sup>	Sample Product Weight	Material Weight
Can be required by client needs in different country standard	8.4 kg	10.0 kg

(a) Material Cost	(b) Production Cost	(c) Packaging Cost	(d) Delivery Cost	(a~d) Unit Price <sup>(3)</sup>	Mould Fee <sup>(4)</sup>
Depend on the steel grade	EUR €3.9/pc	EUR €0.2/pc	Depend on the country and location	EUR €4.1/pc + (a+d)	EUR €3,500

Note:

- 1) The Quotation above is updated on Nov 2021, and only for reference purposes. Please contact us for getting the latest Price, due to different weights in diverse product designs, timely changes in material cost and currency exchange rate, etc.
- 2) Regarding the material type, please refer to *Reference: Worldwide Equivalents Grades of Steel* on Page.53~57.
- 3) The (a~d) Unit Price without Tax.
- 4) If the product orders over 30,000 pieces, the Mould Fee will be returned after the contract is formally signed.

## TECHNICAL SPECIFICATION

For Concept Design & Mould Simulation:

- All dimensions including R angles can be appropriately adjusted according to technical requirements.
- The size of the tolerance can be adjusted according to the client needs.

For Production:

- The product physical performance and surface treatment meet the technical requirements of the drawings.
- The product must have NO burrs, NO crack, NO pits and NO other defects that affect product use.

## CONCEPT DESIGN

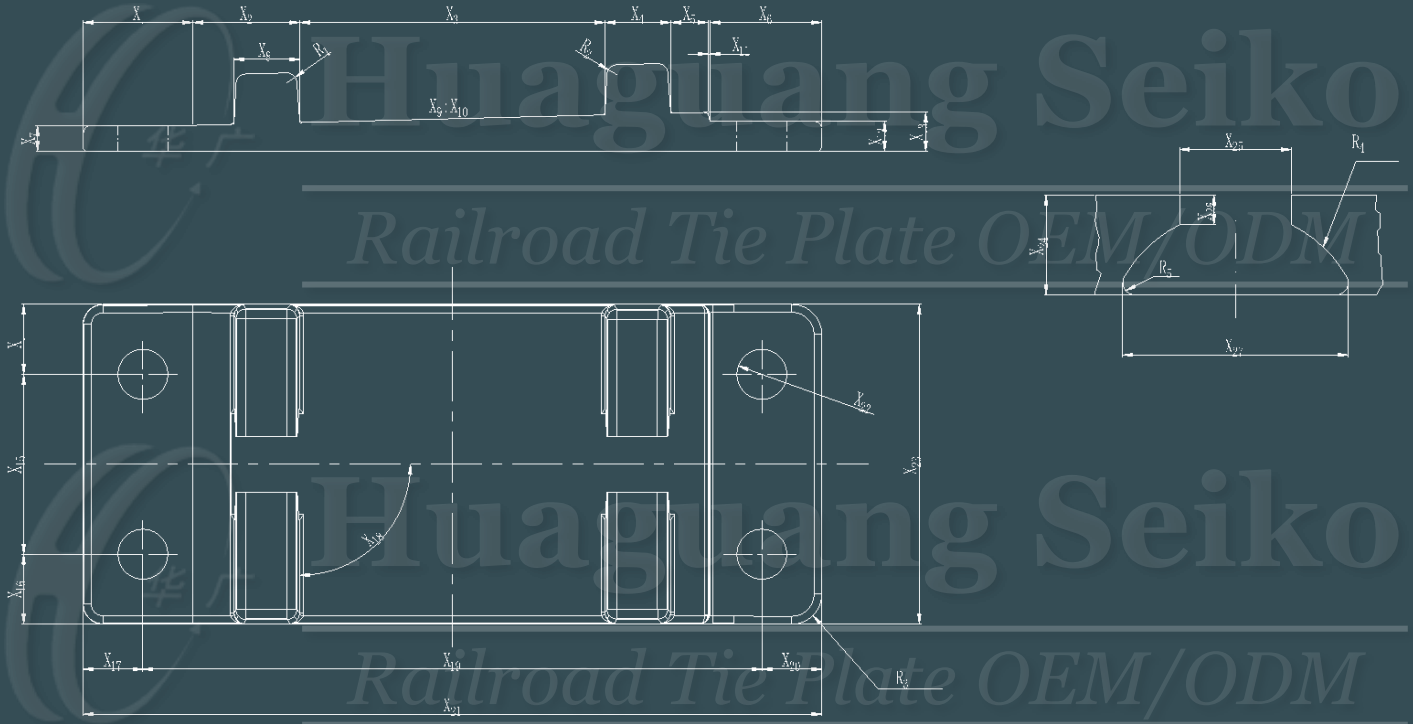

## MOULD SIMULATION



Note: In the interests of product improvement, Huaguang Seiko reserves the right to change the specifications contained herein at any time without prior notice.

## 2. European Standard Railroad Type: 60UNI

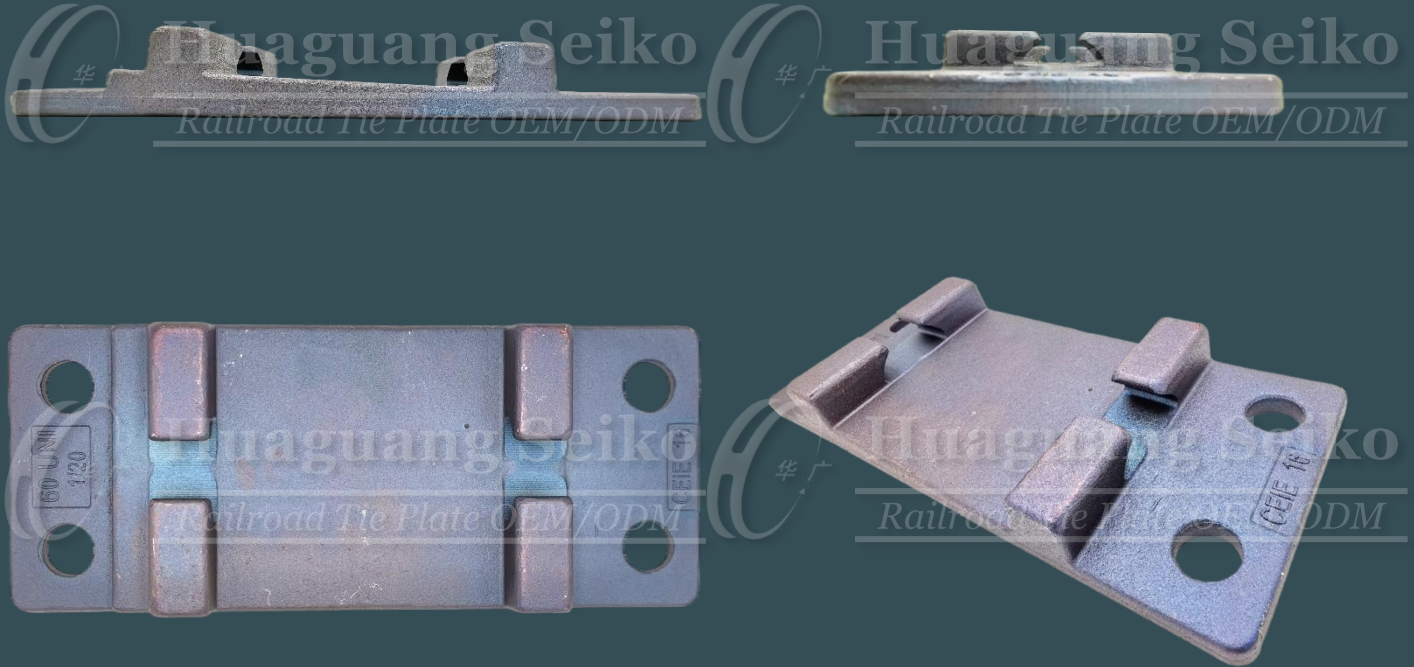

### QUOTATION<sup>(1)</sup>

Material Type <sup>(2)</sup>	Sample Product Weight	Material Weight
Can be required by client needs in different country standard	8.8 kg	10.3 kg

(a) Material Cost	(b) Production Cost	(c) Packaging Cost	(d) Delivery Cost	(a~d) Unit Price <sup>(3)</sup>	Mould Fee <sup>(4)</sup>
Depend on the steel grade	EUR €4.2/pc	EUR €0.2/pc	Depend on the country and location	EUR €4.4/pc + (a+d)	EUR €3,500

Note:

- 1) The Quotation above is updated on Nov 2021, and only for reference purposes. Please contact us for getting the latest Price, due to different weights in diverse product designs, timely changes in material cost and currency exchange rate, etc.
- 2) Regarding the material type, please refer to *Reference: Worldwide Equivalents Grades of Steel* on Page.53~57.
- 3) The (a~d) Unit Price without Tax.
- 4) If the product orders over 30,000 pieces, the Mould Fee will be returned after the contract is formally signed.

### TECHNICAL SPECIFICATION

For Concept Design & Mould Simulation:

- All dimensions including R angles can be appropriately adjusted according to technical requirements.
- The size of the tolerance can be adjusted according to the client needs.

For Production:

- The product physical performance and surface treatment meet the technical requirements of the drawings.
- The product must have NO burrs, NO crack, NO pits and NO other defects that affect product use.



## CONCEPT DESIGN

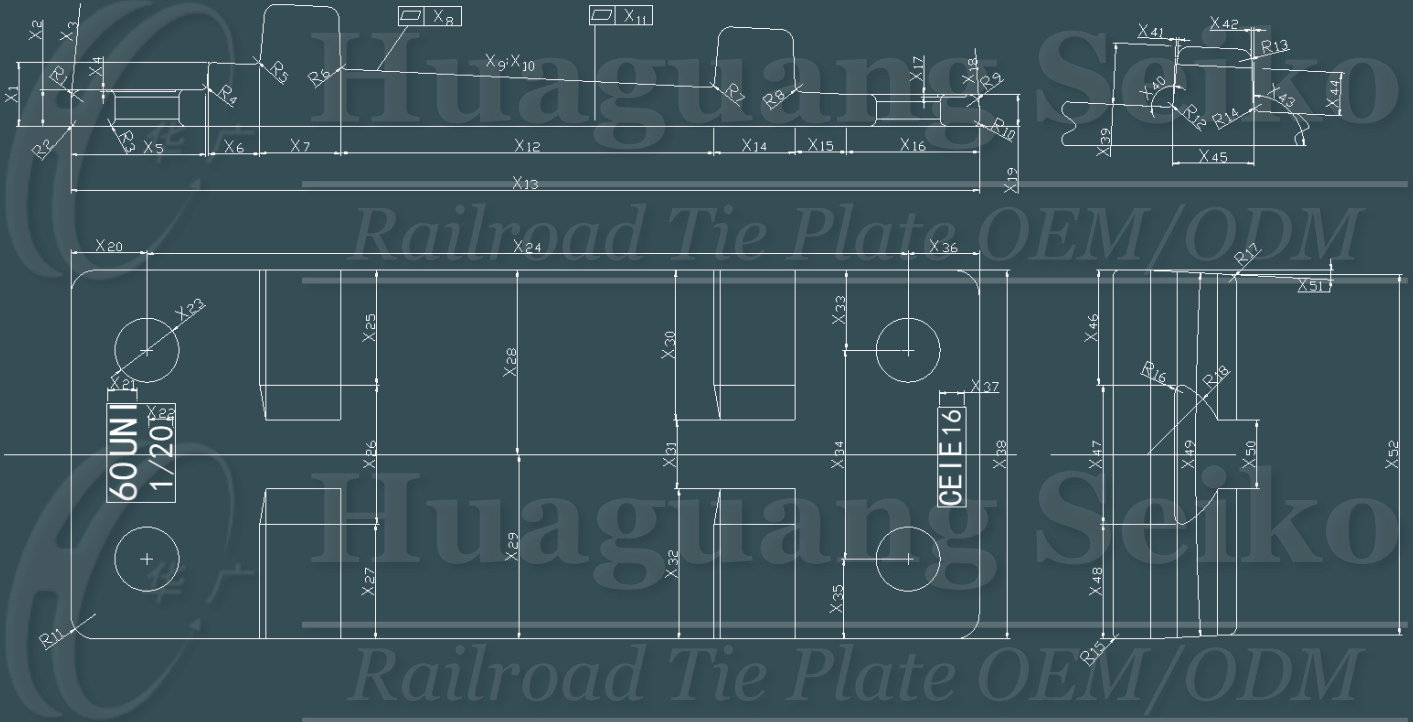

## MOULD SIMULATION



Note: In the interests of product improvement, Huaguang Seiko reserves the right to change the specifications contained herein at any time without prior notice.

### 3. European High-speed Railroad Type: EHR-RP4R



#### QUOTATION<sup>(1)</sup>

Material Type <sup>(2)</sup>	Sample Product Weight	Material Weight
Can be required by client needs in different country standard	9.1 kg	10.5 kg

(a) Material Cost	(b) Production Cost	(c) Packaging Cost	(d) Delivery Cost	(a~d) Unit Price <sup>(3)</sup>	Mould Fee <sup>(4)</sup>
Depend on the steel grade	EUR €4.5/pc	EUR €0.2/pc	Depend on the country and location	EUR €4.7/pc + (a+d)	EUR €3,750

Note:

- 1) The Quotation above is updated on Nov 2021, and only for reference purposes. Please contact us for getting the latest Price, due to different weights in diverse product designs, timely changes in material cost and currency exchange rate, etc.
- 2) Regarding the material type, please refer to *Reference: Worldwide Equivalents Grades of Steel* on Page.53~57.
- 3) The (a~d) Unit Price without Tax.
- 4) If the product orders over 30,000 pieces, the Mould Fee will be returned after the contract is formally signed.

#### TECHNICAL SPECIFICATION

For Concept Design & Mould Simulation:

- All dimensions including R angles can be appropriately adjusted according to technical requirements.
- The size of the tolerance can be adjusted according to the client needs.

For Production:

- The product physical performance and surface treatment meet the technical requirements of the drawings.
- The product must have NO burrs, NO crack, NO pits and NO other defects that affect product use.

## CONCEPT DESIGN

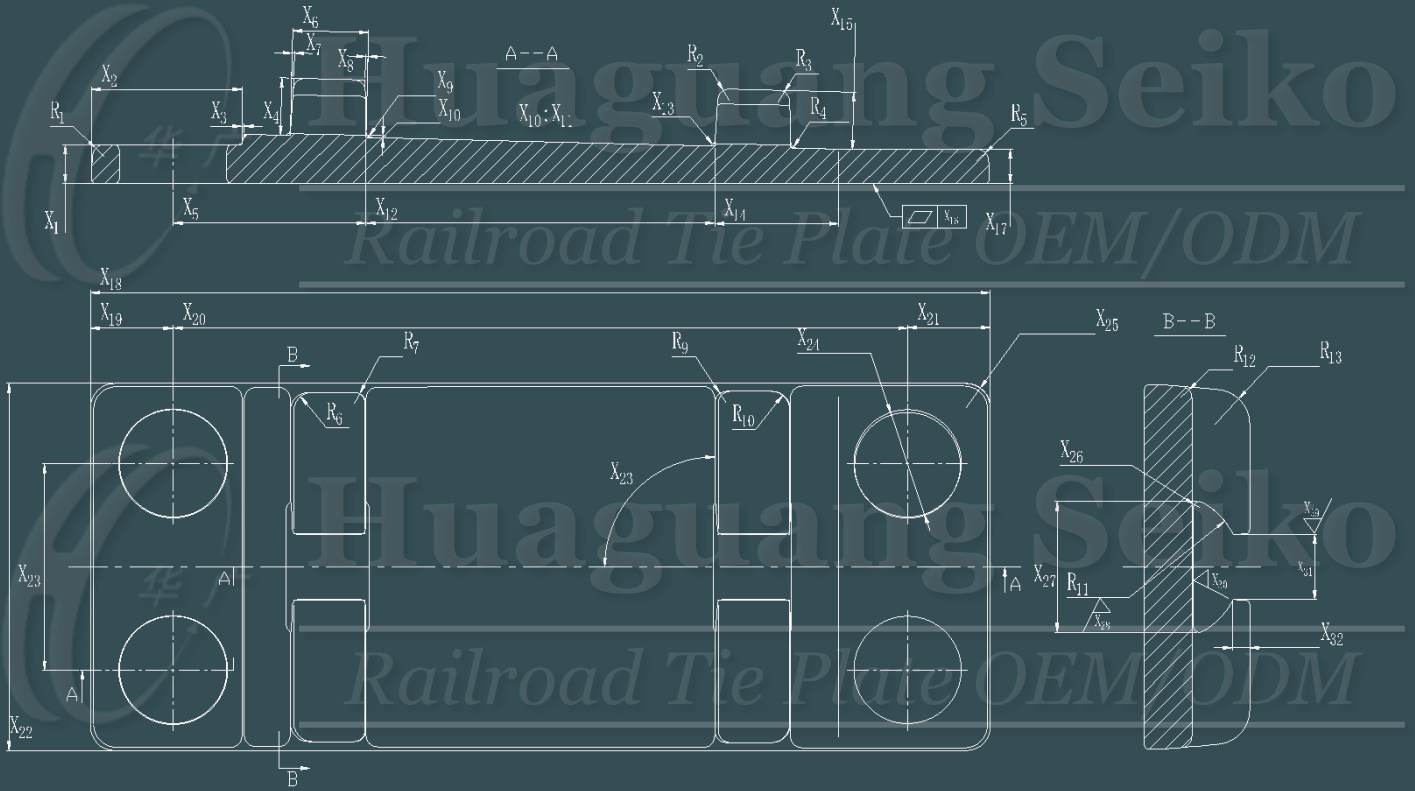

## MOULD SIMULATION



Note: In the interests of product improvement, Huaguang Seiko reserves the right to change the specifications contained herein at any time without prior notice.

## 4. European High-speed Railroad Type: EHR-HB2R



### QUOTATION<sup>(1)</sup>

Material Type <sup>(2)</sup>	Sample Product Weight	Material Weight
Can be required by client needs in different country standard	8.5 kg	10.0 kg

(a) Material Cost	(b) Production Cost	(c) Packaging Cost	(d) Delivery Cost	(a~d) Unit Price <sup>(3)</sup>	Mould Fee <sup>(4)</sup>
Depend on the steel grade	EUR €4.0/pc	EUR €0.2/pc	Depend on the country and location	EUR €4.2/pc + (a+d)	EUR €3,500

Note:

- 1) The Quotation above is updated on Nov 2021, and only for reference purposes. Please contact us for getting the latest Price, due to different weights in diverse product designs, timely changes in material cost and currency exchange rate, etc.
- 2) Regarding the material type, please refer to *Reference: Worldwide Equivalents Grades of Steel* on Page.53~57.
- 3) The (a~d) Unit Price without Tax.
- 4) If the product orders over 30,000 pieces, the Mould Fee will be returned after the contract is formally signed.

### TECHNICAL SPECIFICATION

For Concept Design & Mould Simulation:

- All dimensions including R angles can be appropriately adjusted according to technical requirements.
- The size of the tolerance can be adjusted according to the client needs.

For Production:

- The product physical performance and surface treatment meet the technical requirements of the drawings.
- The product must have NO burrs, NO crack, NO pits and NO other defects that affect product use.

## CONCEPT DESIGN

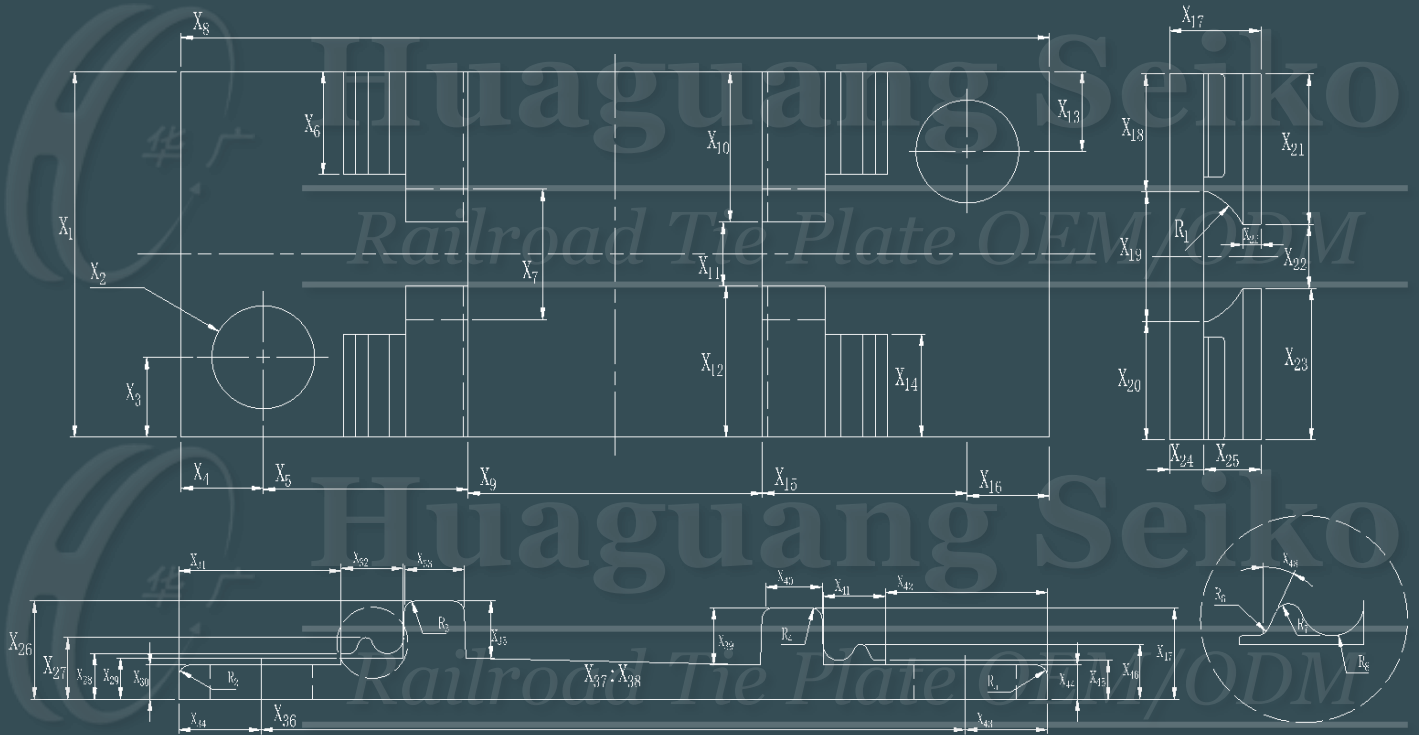

## MOULD SIMULATION



Note: In the interests of product improvement, Huaguang Seiko reserves the right to change the specifications contained herein at any time without prior notice.

## 5. European High-speed Railroad Type: EHR-FS4R

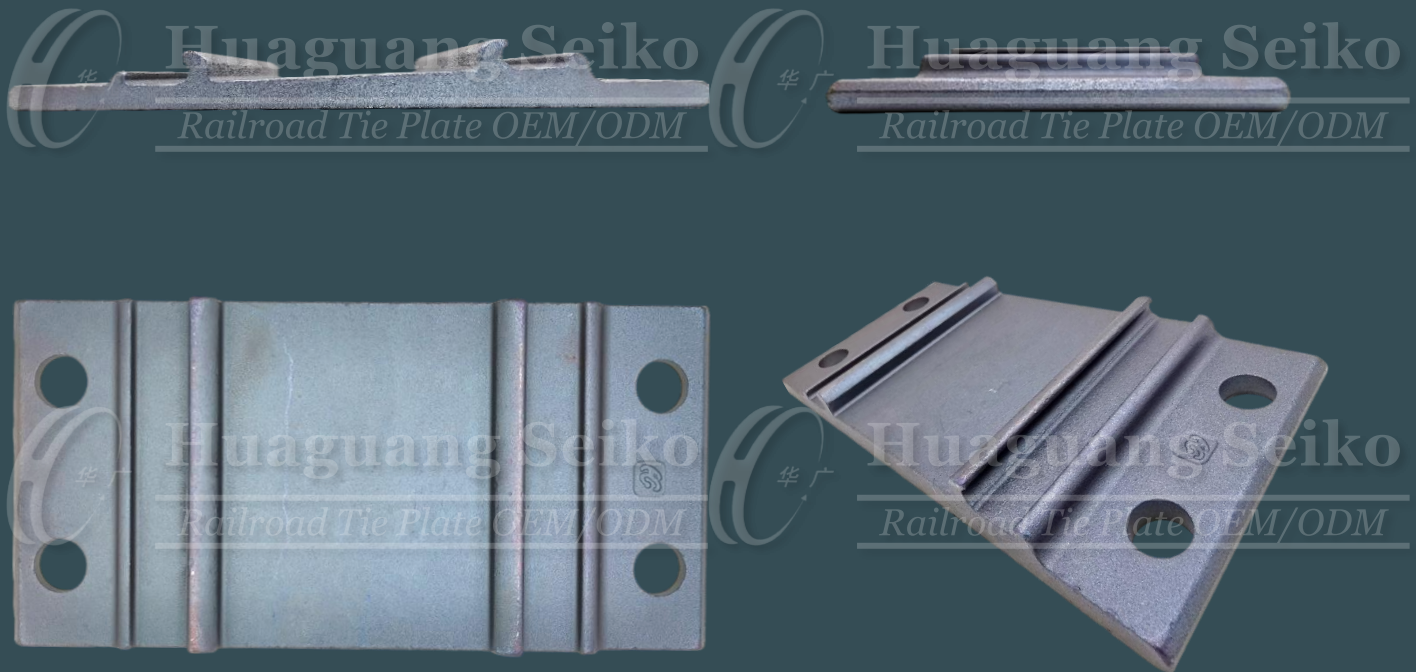

### QUOTATION<sup>(1)</sup>

Material Type <sup>(2)</sup>	Sample Product Weight	Material Weight
Can be required by client needs in different country standard	7.3 kg	8.5 kg

(a) Material Cost	(b) Production Cost	(c) Packaging Cost	(d) Delivery Cost	(a~d) Unit Price <sup>(3)</sup>	Mould Fee <sup>(4)</sup>
Depend on the steel grade	EUR €3.5/pc	EUR €0.2/pc	Depend on the country and location	EUR €3.7/pc + (a+d)	EUR €3,250

Note:

- 1) The Quotation above is updated on Nov 2021, and only for reference purposes. Please contact us for getting the latest Price, due to different weights in diverse product designs, timely changes in material cost and currency exchange rate, etc.
- 2) Regarding the material type, please refer to *Reference: Worldwide Equivalents Grades of Steel* on Page.53~57.
- 3) The (a~d) Unit Price without Tax.
- 4) If the product orders over 30,000 pieces, the Mould Fee will be returned after the contract is formally signed.

### TECHNICAL SPECIFICATION

For Concept Design & Mould Simulation:

- All dimensions including R angles can be appropriately adjusted according to technical requirements.
- The size of the tolerance can be adjusted according to the client needs.

For Production:

- The product physical performance and surface treatment meet the technical requirements of the drawings.
- The product must have NO burrs, NO crack, NO pits and NO other defects that affect product use.

## CONCEPT DESIGN

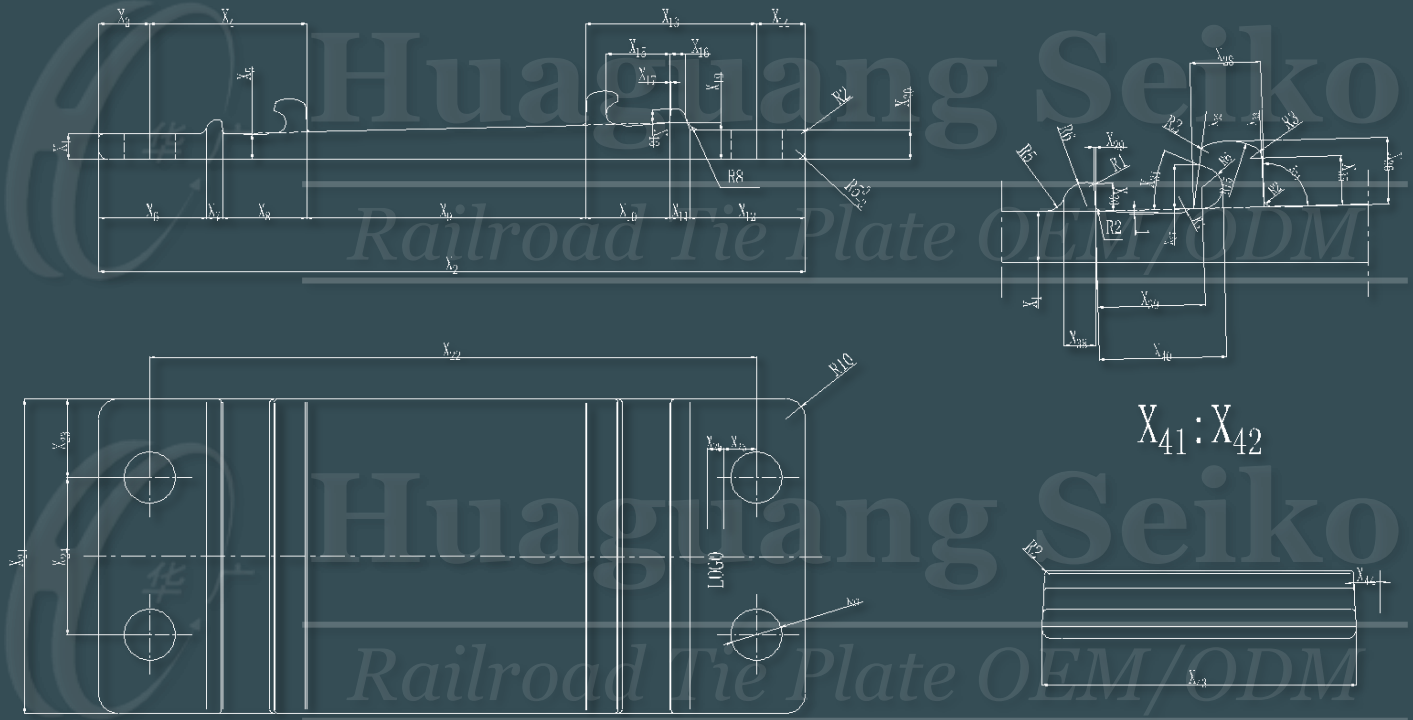

## MOULD SIMULATION



Note: In the interests of product improvement, Huaguang Seiko reserves the right to change the specifications contained herein at any time without prior notice.

## 6. North American Metropolitan Transportation Type: NAMT-6R

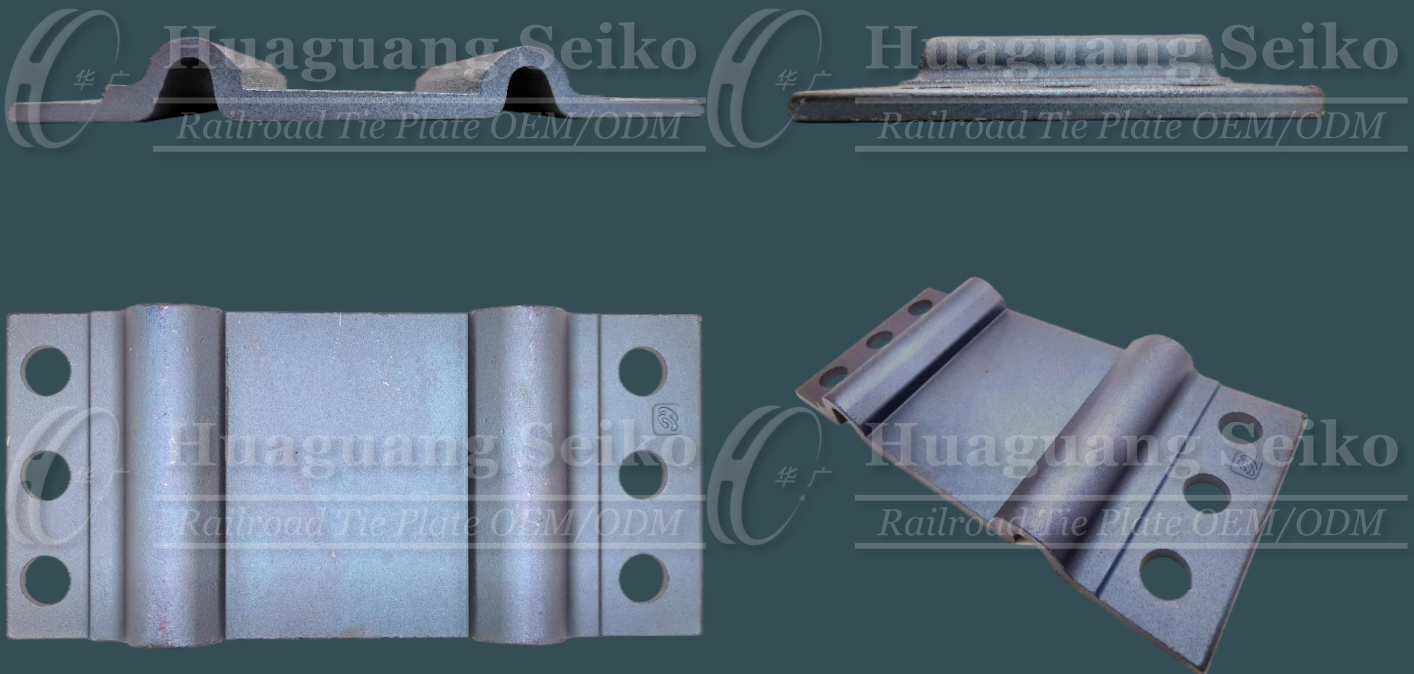

### QUOTATION<sup>(1)</sup>

Material Type <sup>(2)</sup>	Sample Product Weight	Material Weight
Can be required by client needs in different country standard	8.5 kg	10.0 kg

(a) Material Cost	(b) Production Cost	(c) Packaging Cost	(d) Delivery Cost	(a~d) Unit Price <sup>(3)</sup>	Mould Fee <sup>(4)</sup>
Depend on the steel grade	EUR €4.0/pc	EUR €0.2/pc	Depend on the country and location	EUR €4.2/pc + (a+d)	EUR €3,500

Note:

- 1) The Quotation above is updated on Nov 2021, and only for reference purposes. Please contact us for getting the latest Price, due to different weights in diverse product designs, timely changes in material cost and currency exchange rate, etc.
- 2) Regarding the material type, please refer to *Reference: Worldwide Equivalents Grades of Steel* on Page.53~57.
- 3) The (a~d) Unit Price without Tax.
- 4) If the product orders over 30,000 pieces, the Mould Fee will be returned after the contract is formally signed.

### TECHNICAL SPECIFICATION

For Concept Design & Mould Simulation:

- All dimensions including R angles can be appropriately adjusted according to technical requirements.
- The size of the tolerance can be adjusted according to the client needs.

For Production:

- The product physical performance and surface treatment meet the technical requirements of the drawings.
- The product must have NO burrs, NO crack, NO pits and NO other defects that affect product use.



## CONCEPT DESIGN

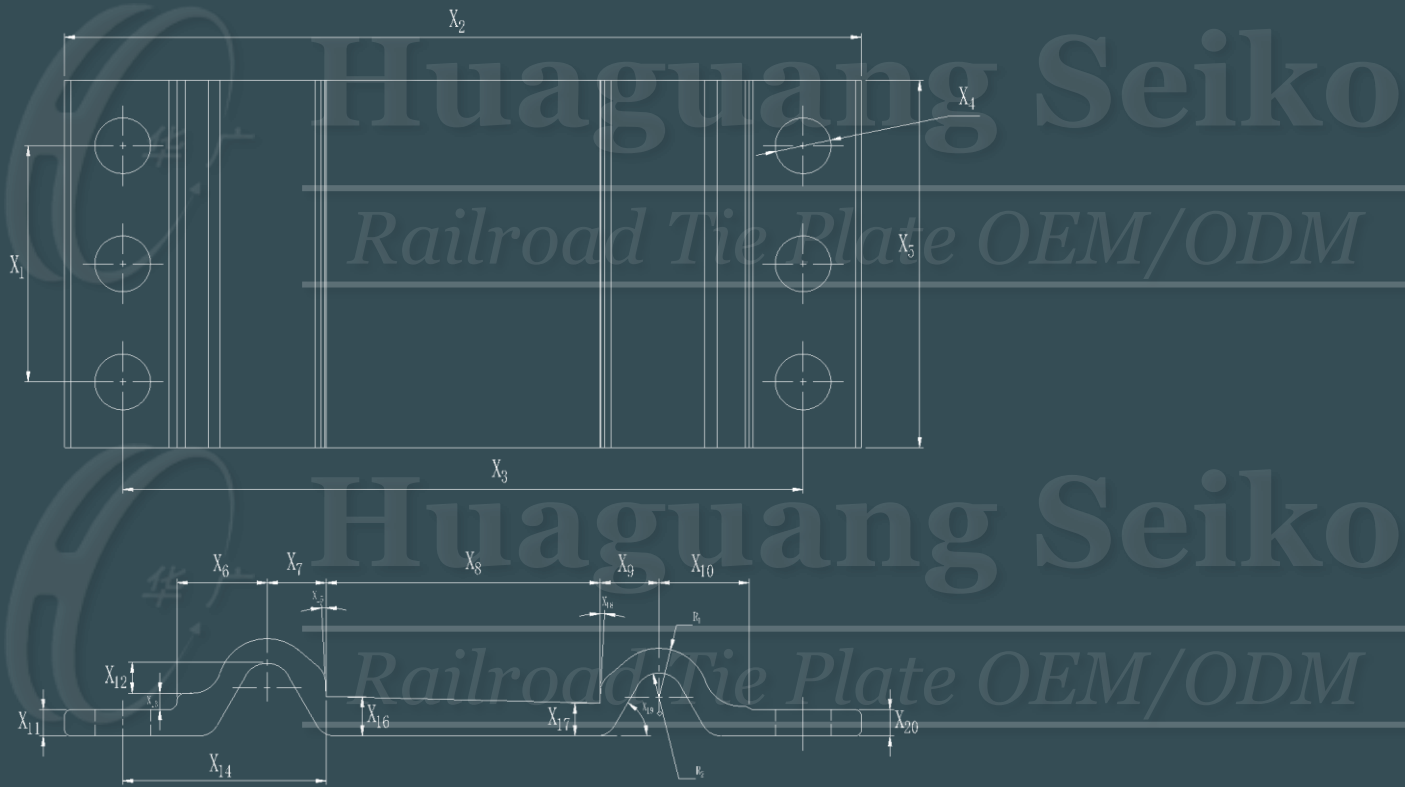

## MOULD SIMULATION



Note: In the interests of product improvement, Huaguang Seiko reserves the right to change the specifications contained herein at any time without prior notice.

## 7. North American Metropolitan Transportation Type: NAMT-4R

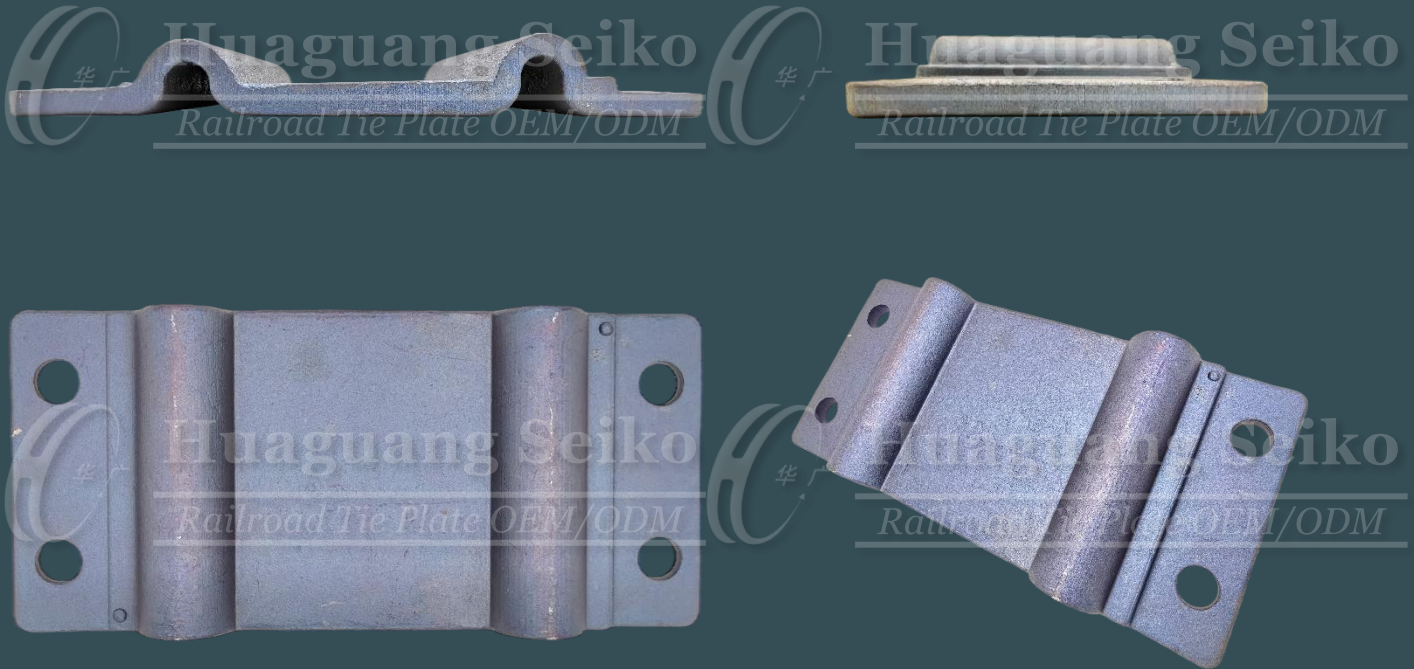

### QUOTATION<sup>(1)</sup>

Material Type <sup>(2)</sup>	Sample Product Weight	Material Weight
Can be required by client needs in different country standard	7.1 kg	8.5 kg

(a) Material Cost	(b) Production Cost	(c) Packaging Cost	(d) Delivery Cost	(a~d) Unit Price <sup>(3)</sup>	Mould Fee <sup>(4)</sup>
Depend on the steel grade	EUR €3.2/pc	EUR €0.2/pc	Depend on the country and location	EUR €3.4/pc + (a+d)	EUR €3,250

Note:

- 1) The Quotation above is updated on Nov 2021, and only for reference purposes. Please contact us for getting the latest Price, due to different weights in diverse product designs, timely changes in material cost and currency exchange rate, etc.
- 2) Regarding the material type, please refer to *Reference: Worldwide Equivalents Grades of Steel* on Page.53~57.
- 3) The (a~d) Unit Price without Tax.
- 4) If the product orders over 30,000 pieces, the Mould Fee will be returned after the contract is formally signed.

### TECHNICAL SPECIFICATION

For Concept Design & Mould Simulation:

- All dimensions including R angles can be appropriately adjusted according to technical requirements.
- The size of the tolerance can be adjusted according to the client needs.

For Production:

- The product physical performance and surface treatment meet the technical requirements of the drawings.
- The product must have NO burrs, NO crack, NO pits and NO other defects that affect product use.

## CONCEPT DESIGN

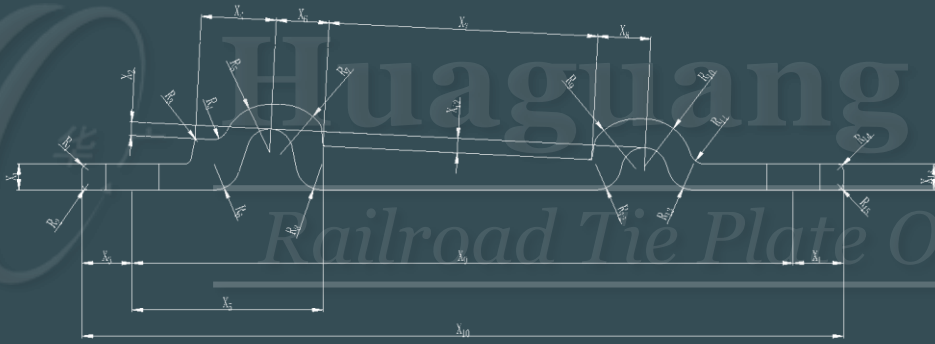

## MOULD SIMULATION



Note: In the interests of product improvement, Huaguang Seiko reserves the right to change the specifications contained herein at any time without prior notice.

## 8. North American Standard Railway Type: NASR-8S

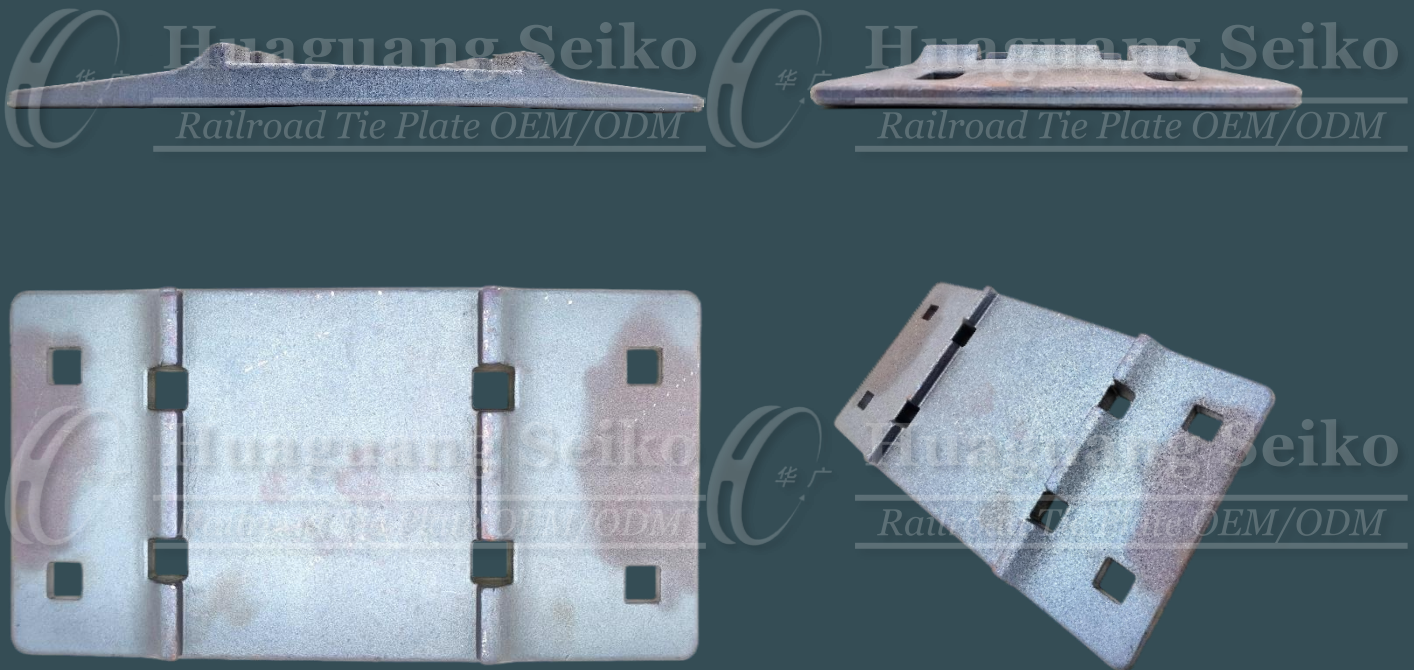

### QUOTATION<sup>(1)</sup>

Material Type <sup>(2)</sup>	Sample Product Weight	Material Weight
Can be required by client needs in different country standard	10.6 kg	12.2 kg

(a) Material Cost	(b) Production Cost	(c) Packaging Cost	(d) Delivery Cost	(a~d) Unit Price <sup>(3)</sup>	Mould Fee <sup>(4)</sup>
Depend on the steel grade	EUR €5.2/pc	EUR €0.2/pc	Depend on the country and location	EUR €5.4/pc + (a+d)	EUR €4,000

Note:

- 1) The Quotation above is updated on Nov 2021, and only for reference purposes. Please contact us for getting the latest Price, due to different weights in diverse product designs, timely changes in material cost and currency exchange rate, etc.
- 2) Regarding the material type, please refer to *Reference: Worldwide Equivalents Grades of Steel* on Page.53~57.
- 3) The (a~d) Unit Price without Tax.
- 4) If the product orders over 30,000 pieces, the Mould Fee will be returned after the contract is formally signed.

### TECHNICAL SPECIFICATION

For Concept Design & Mould Simulation:

- All dimensions including R angles can be appropriately adjusted according to technical requirements.
- The size of the tolerance can be adjusted according to the client needs.

For Production:

- The product physical performance and surface treatment meet the technical requirements of the drawings.
- The product must have NO burrs, NO crack, NO pits and NO other defects that affect product use.

## CONCEPT DESIGN

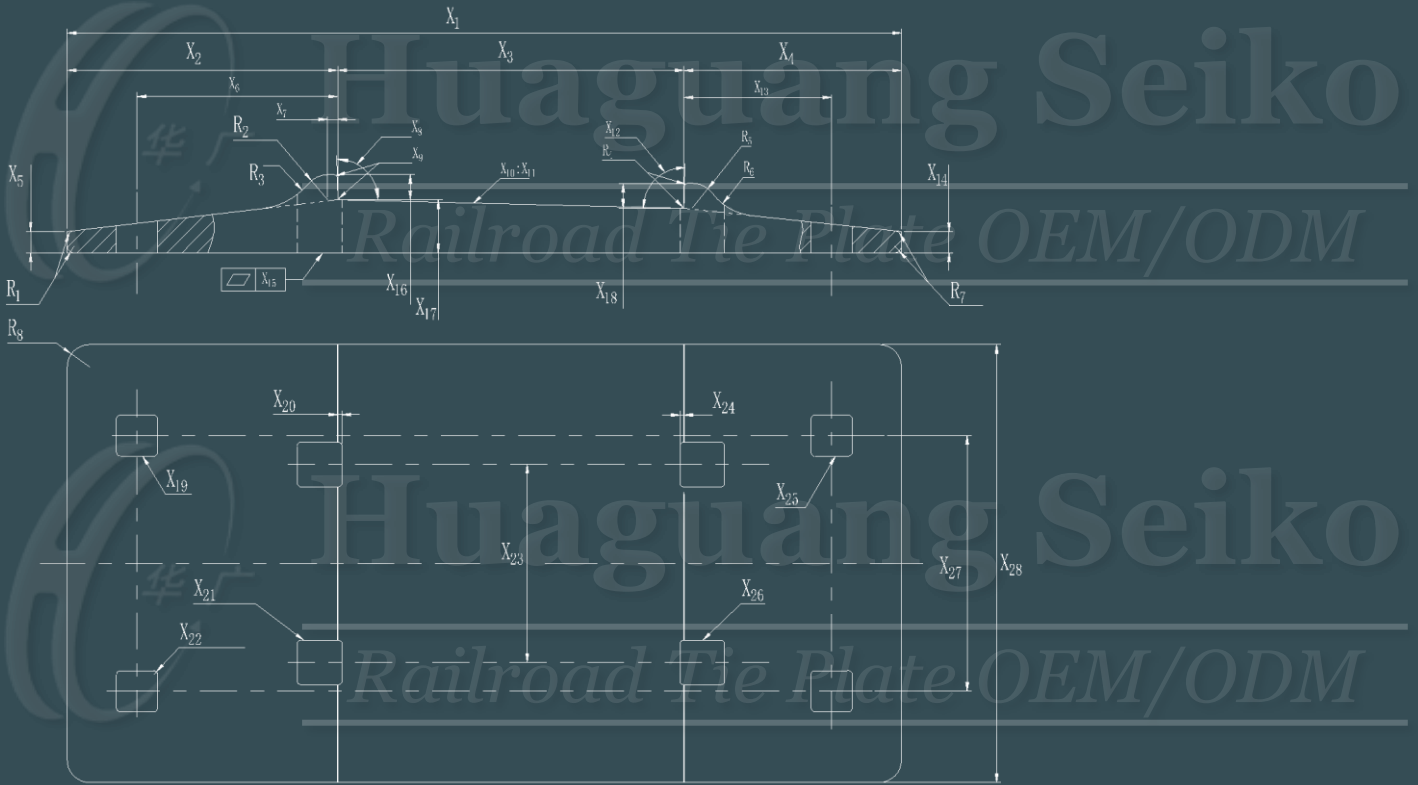

## MOULD SIMULATION



Note: In the interests of product improvement, Huaguang Seiko reserves the right to change the specifications contained herein at any time without prior notice.

## 9. South American Standard Subway Type: SASS-4R



### QUOTATION<sup>(1)</sup>

Material Type <sup>(2)</sup>	Sample Product Weight	Material Weight
Can be required by client needs in different country standard	7.9 kg	9.2 kg

(a) Material Cost	(b) Production Cost	(c) Packaging Cost	(d) Delivery Cost	(a~d) Unit Price <sup>(3)</sup>	Mould Fee <sup>(4)</sup>
Depend on the steel grade	EUR €3.8/pc	EUR €0.2/pc	Depend on the country and location	EUR €4.0/pc + (a+d)	EUR €3,250

Note:

- 1) The Quotation above is updated on Nov 2021, and only for reference purposes. Please contact us for getting the latest Price, due to different weights in diverse product designs, timely changes in material cost and currency exchange rate, etc.
- 2) Regarding the material type, please refer to *Reference: Worldwide Equivalents Grades of Steel* on Page.53~57.
- 3) The (a~d) Unit Price without Tax.
- 4) If the product orders over 30,000 pieces, the Mould Fee will be returned after the contract is formally signed.

### TECHNICAL SPECIFICATION

For Concept Design & Mould Simulation:

- All dimensions including R angles can be appropriately adjusted according to technical requirements.
- The size of the tolerance can be adjusted according to the client needs.

For Production:

- The product physical performance and surface treatment meet the technical requirements of the drawings.
- The product must have NO burrs, NO crack, NO pits and NO other defects that affect product use.

## CONCEPT DESIGN

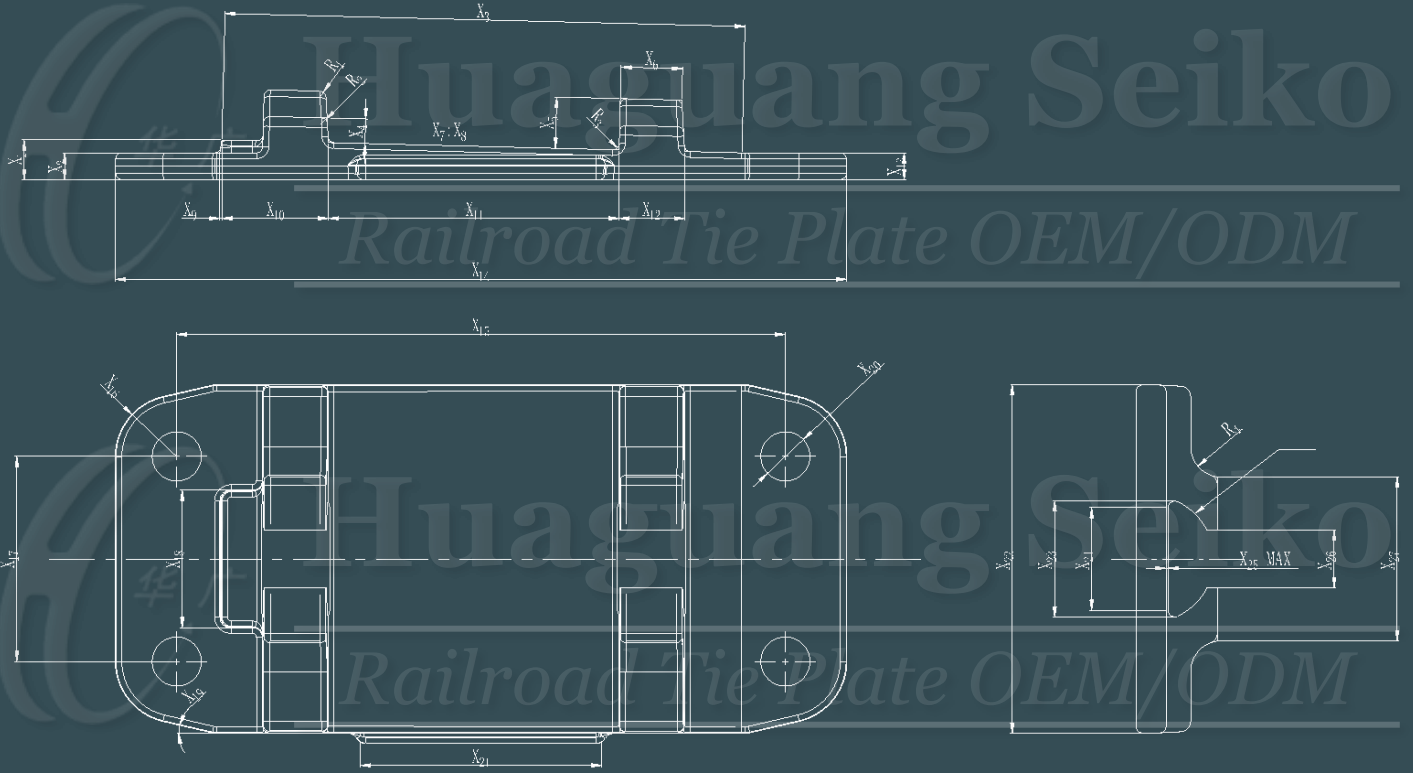

## MOULD SIMULATION



Note: In the interests of product improvement, Huaguang Seiko reserves the right to change the specifications contained herein at any time without prior notice.

## 10. Japanese Bullet Train (Shinkansen) Type: JBT-20

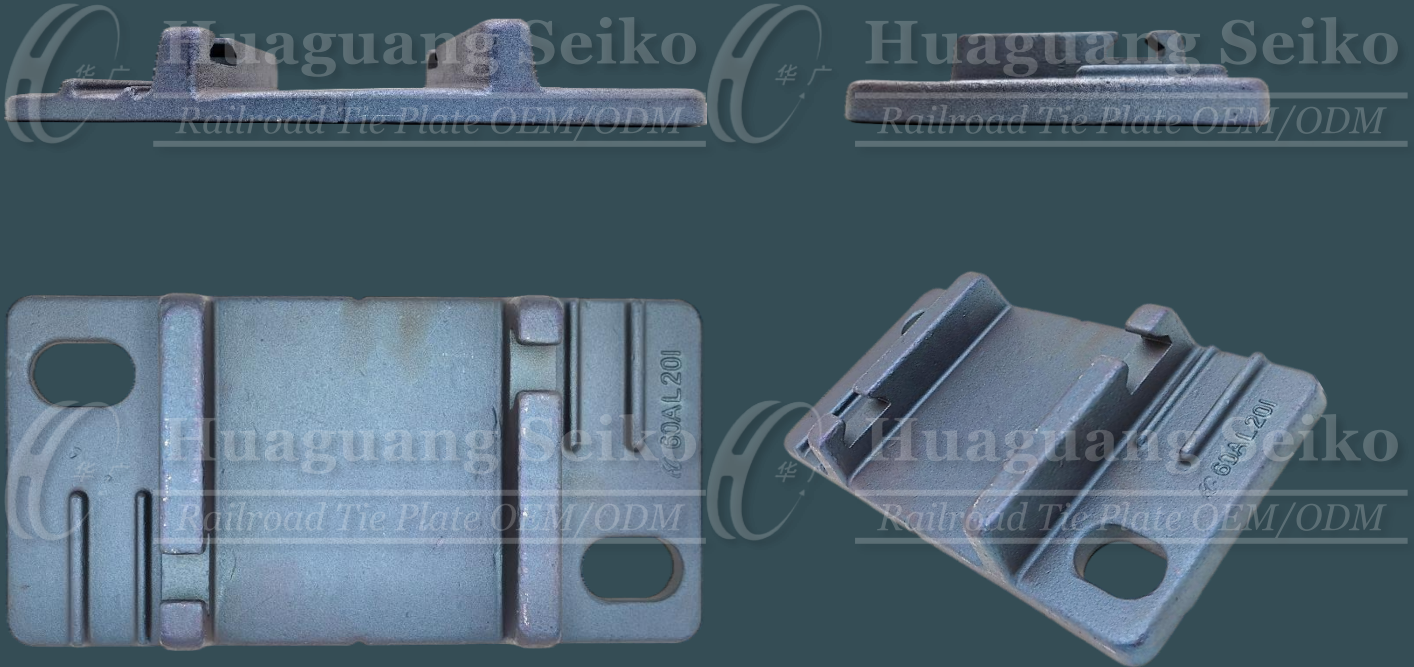

### QUOTATION<sup>(1)</sup>

Material Type <sup>(2)</sup>	Sample Product Weight	Material Weight
Can be required by client needs in different country standard	9.8 kg	11.5 kg

(a) Material Cost	(b) Production Cost	(c) Packaging Cost	(d) Delivery Cost	(a~d) Unit Price <sup>(3)</sup>	Mould Fee <sup>(4)</sup>
Depend on the steel grade	EUR €4.7/pc	EUR €0.2/pc	Depend on the country and location	EUR €4.9/pc + (a+d)	EUR €3,750

Note:

- 1) The Quotation above is updated on Nov 2021, and only for reference purposes. Please contact us for getting the latest Price, due to different weights in diverse product designs, timely changes in material cost and currency exchange rate, etc.
- 2) Regarding the material type, please refer to *Reference: Worldwide Equivalents Grades of Steel* on Page.53~57.
- 3) The (a~d) Unit Price without Tax.
- 4) If the product orders over 30,000 pieces, the Mould Fee will be returned after the contract is formally signed.

### TECHNICAL SPECIFICATION

For Concept Design & Mould Simulation:

- All dimensions including R angles can be appropriately adjusted according to technical requirements.
- The size of the tolerance can be adjusted according to the client needs.

For Production:

- The product physical performance and surface treatment meet the technical requirements of the drawings.
- The product must have NO burrs, NO crack, NO pits and NO other defects that affect product use.



## CONCEPT DESIGN

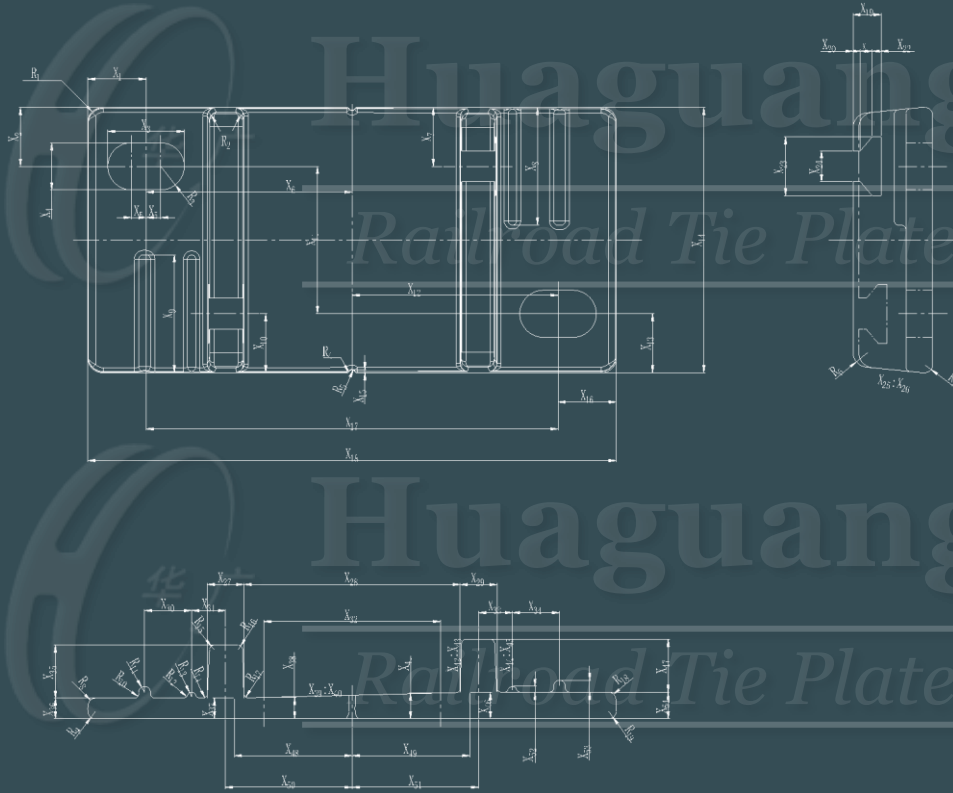

## MOULD SIMULATION



Note: In the interests of product improvement, Huaguang Seiko reserves the right to change the specifications contained herein at any time without prior notice.

## 11. Japanese Bullet Train (Shinkansen) Type: JBT-40

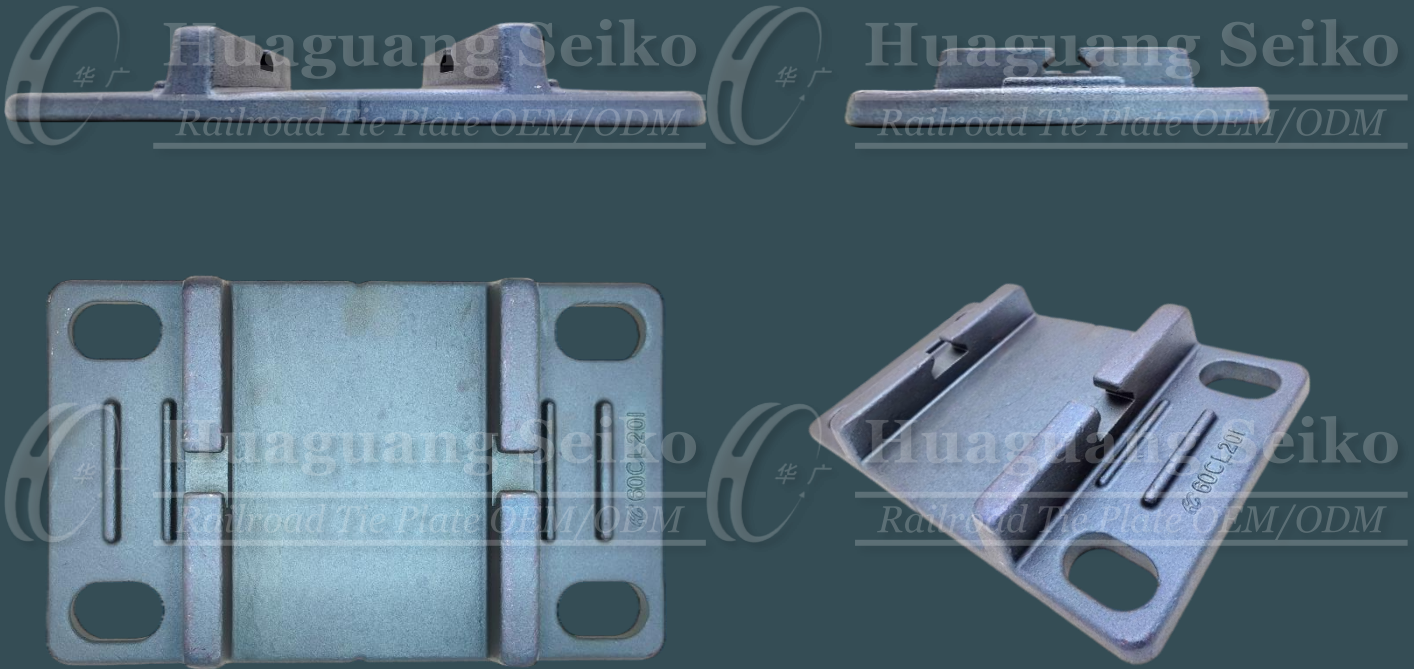

### QUOTATION<sup>(1)</sup>

Material Type <sup>(2)</sup>	Sample Product Weight	Material Weight
Can be required by client needs in different country standard	11.8 kg	13.5 kg

(a) Material Cost	(b) Production Cost	(c) Packaging Cost	(d) Delivery Cost	(a~d) Unit Price <sup>(3)</sup>	Mould Fee <sup>(4)</sup>
Depend on the steel grade	EUR €5.9/pc	EUR €0.2/pc	Depend on the country and location	EUR €6.1/pc + (a+d)	EUR €4,250

Note:

- 1) The Quotation above is updated on Nov 2021, and only for reference purposes. Please contact us for getting the latest Price, due to different weights in diverse product designs, timely changes in material cost and currency exchange rate, etc.
- 2) Regarding the material type, please refer to *Reference: Worldwide Equivalents Grades of Steel* on Page.53~57.
- 3) The (a~d) Unit Price without Tax.
- 4) If the product orders over 30,000 pieces, the Mould Fee will be returned after the contract is formally signed.

### TECHNICAL SPECIFICATION

For Concept Design & Mould Simulation:

- All dimensions including R angles can be appropriately adjusted according to technical requirements.
- The size of the tolerance can be adjusted according to the client needs.

For Production:

- The product physical performance and surface treatment meet the technical requirements of the drawings.
- The product must have NO burrs, NO crack, NO pits and NO other defects that affect product use.

## CONCEPT DESIGN

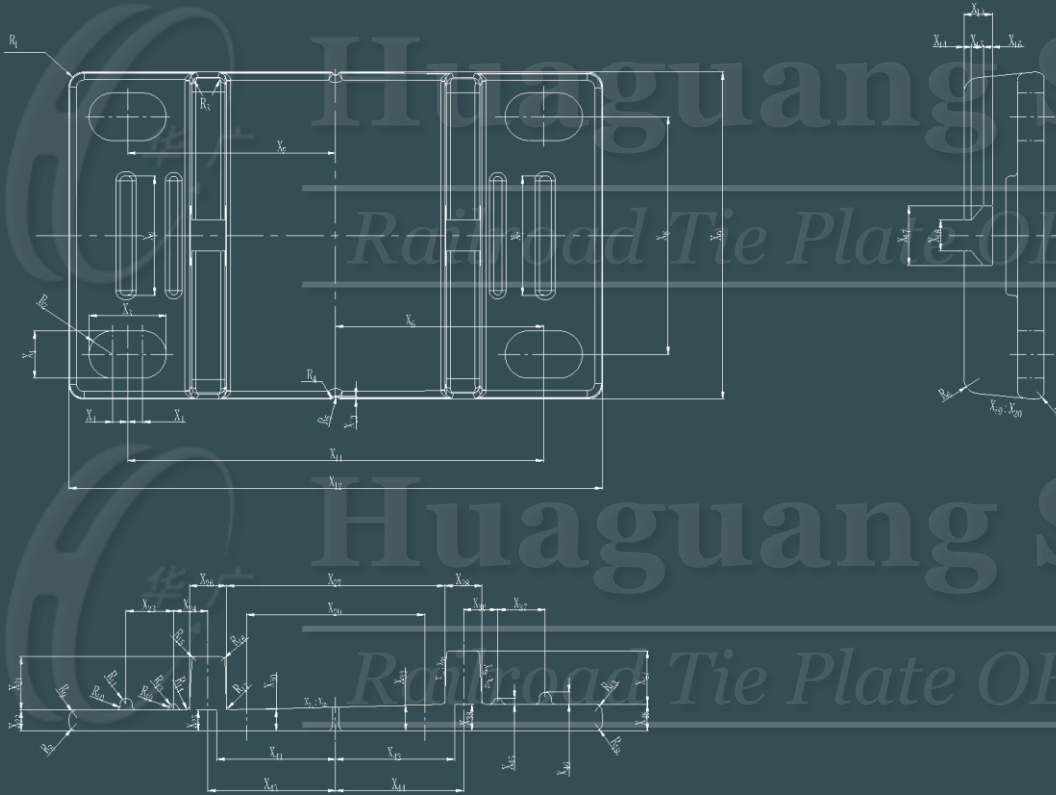

## MOULD SIMULATION



Note: In the interests of product improvement, Huaguang Seiko reserves the right to change the specifications contained herein at any time without prior notice.

## 12. Chinese High-speed Railway Type: CHR-20



### QUOTATION<sup>(1)</sup>

Material Type <sup>(2)</sup>	Sample Product Weight	Material Weight
Can be required by client needs in different country standard	12.0 kg	13.8 kg

(a) Material Cost	(b) Production Cost	(c) Packaging Cost	(d) Delivery Cost	(a~d) Unit Price <sup>(3)</sup>	Mould Fee <sup>(4)</sup>
Depend on the steel grade	EUR €6.0/pc	EUR €0.2/pc	Depend on the country and location	EUR €6.2/pc + (a+d)	EUR €4,250

Note:

- 1) The Quotation above is updated on Nov 2021, and only for reference purposes. Please contact us for getting the latest Price, due to different weights in diverse product designs, timely changes in material cost and currency exchange rate, etc.
- 2) Regarding the material type, please refer to *Reference: Worldwide Equivalents Grades of Steel* on Page.53~57.
- 3) The (a~d) Unit Price without Tax.
- 4) If the product orders over 30,000 pieces, the Mould Fee will be returned after the contract is formally signed.

### TECHNICAL SPECIFICATION

For Concept Design & Mould Simulation:

- All dimensions including R angles can be appropriately adjusted according to technical requirements.
- The size of the tolerance can be adjusted according to the client needs.

For Production:

- The product physical performance and surface treatment meet the technical requirements of the drawings.
- The product must have NO burrs, NO crack, NO pits and NO other defects that affect product use.

## CONCEPT DESIGN

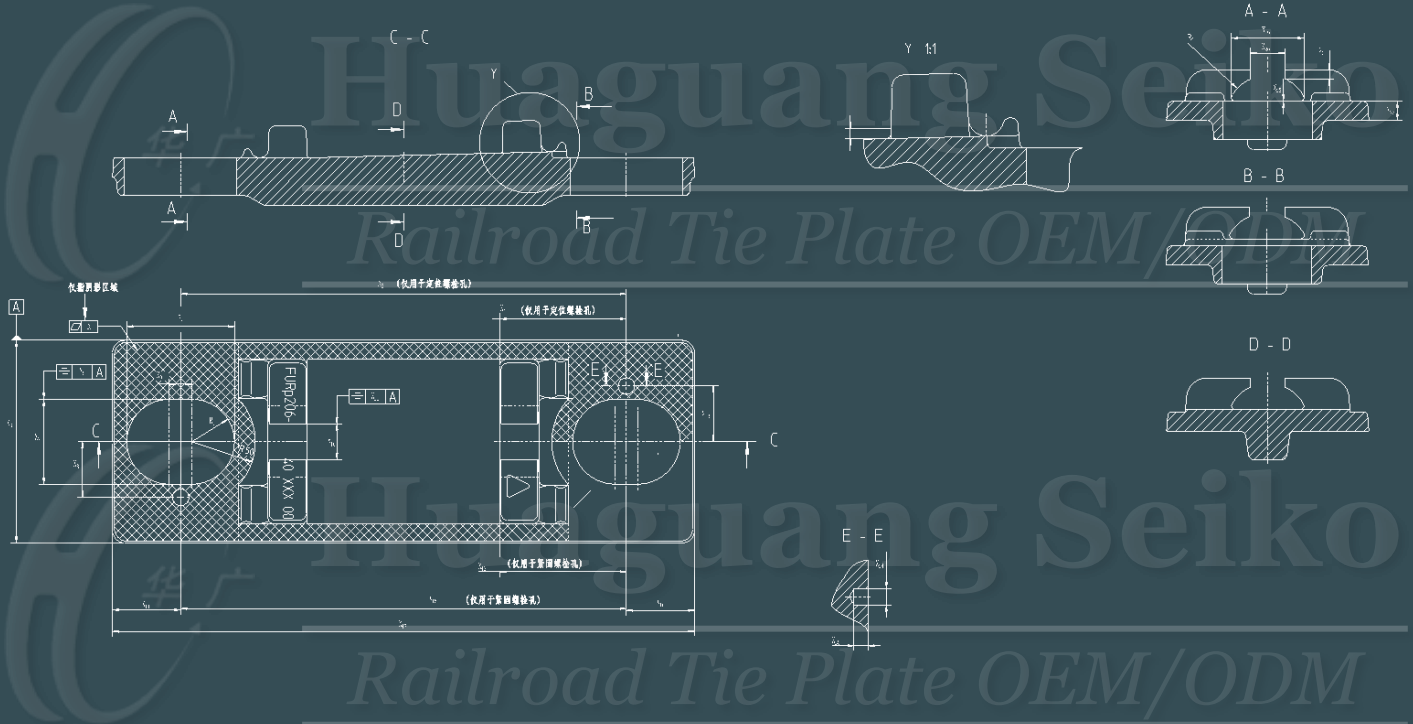

## MOULD SIMULATION



Note: In the interests of product improvement, Huaguang Seiko reserves the right to change the specifications contained herein at any time without prior notice.

### 13. Chinese High-speed Railway Type: CHR-2R



#### QUOTATION<sup>(1)</sup>

Material Type <sup>(2)</sup>	Sample Product Weight	Material Weight
Can be required by client needs in different country standard	19.5 kg	21.5 kg

(a) Material Cost	(b) Production Cost	(c) Packaging Cost	(d) Delivery Cost	(a~d) Unit Price <sup>(3)</sup>	Mould Fee <sup>(4)</sup>
Depend on the steel grade	EUR €10.4/pc	EUR €0.4/pc	Depend on the country and location	EUR €10.8/pc + (a+d)	EUR €5,250

Note:

- 1) The Quotation above is updated on Nov 2021, and only for reference purposes. Please contact us for getting the latest Price, due to different weights in diverse product designs, timely changes in material cost and currency exchange rate, etc.
- 2) Regarding the material type, please refer to *Reference: Worldwide Equivalents Grades of Steel* on Page.53~57.
- 3) The (a~d) Unit Price without Tax.
- 4) If the product orders over 30,000 pieces, the Mould Fee will be returned after the contract is formally signed.

#### TECHNICAL SPECIFICATION

For Concept Design & Mould Simulation:

- All dimensions including R angles can be appropriately adjusted according to technical requirements.
- The size of the tolerance can be adjusted according to the client needs.

For Production:

- The product physical performance and surface treatment meet the technical requirements of the drawings.
- The product must have NO burrs, NO crack, NO pits and NO other defects that affect product use.

## CONCEPT DESIGN

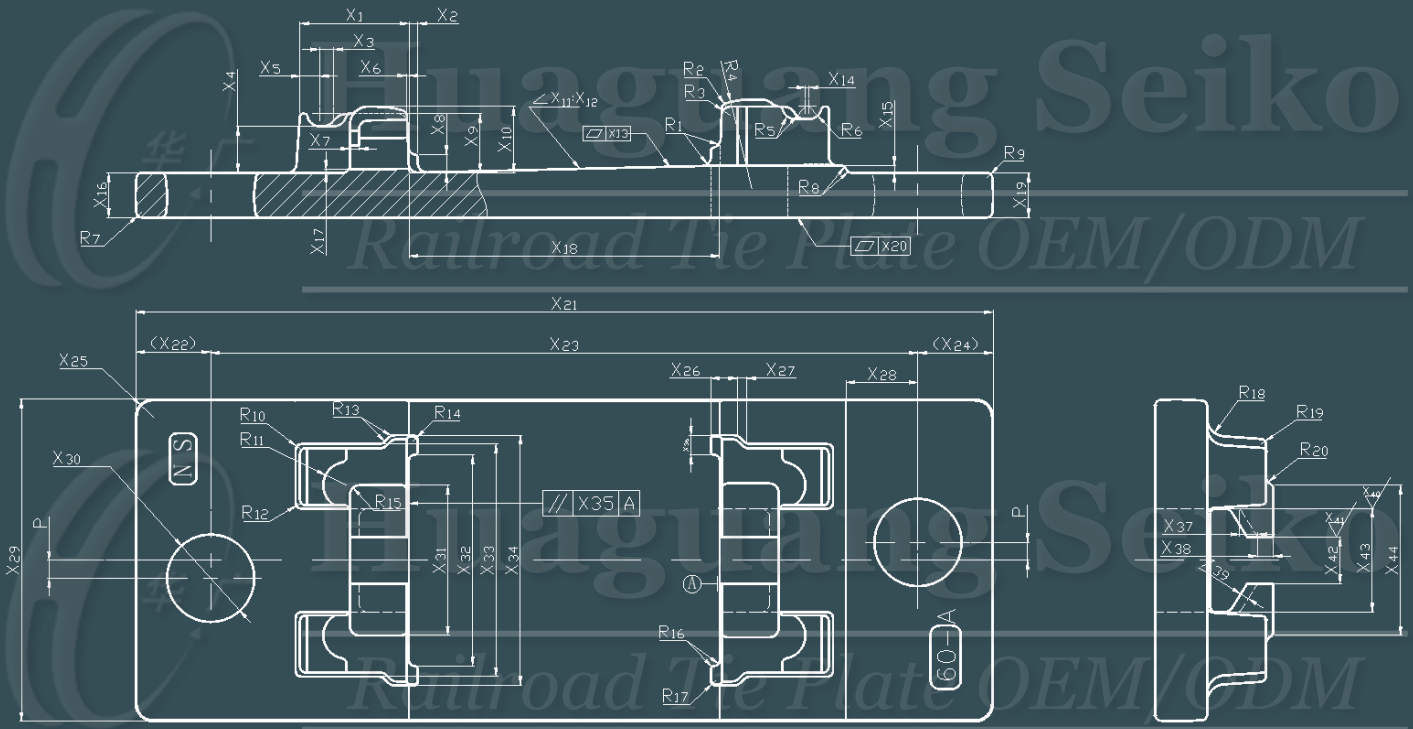

## MOULD SIMULATION



Note: In the interests of product improvement, Huaguang Seiko reserves the right to change the specifications contained herein at any time without prior notice.

## 14. Chinese Standard Subway Type: CST-4R

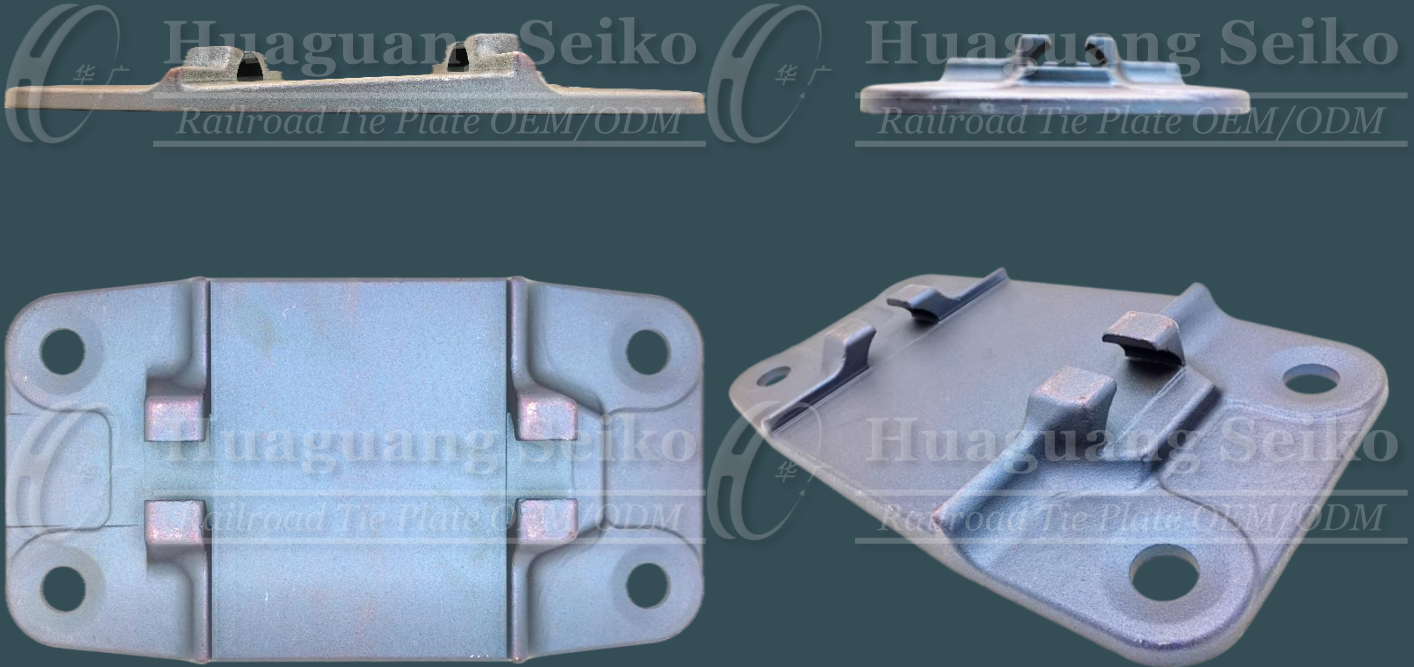

### QUOTATION<sup>(1)</sup>

Material Type <sup>(2)</sup>	Sample Product Weight	Material Weight
Can be required by client needs in different country standard	7.6 kg	8.6 kg

(a) Material Cost	(b) Production Cost	(c) Packaging Cost	(d) Delivery Cost	(a~d) Unit Price <sup>(3)</sup>	Mould Fee <sup>(4)</sup>
Depend on the steel grade	EUR €3.8/pc	EUR €0.2/pc	Depend on the country and location	EUR €4.0/pc + (a+d)	EUR €3,250

Note:

- 1) The Quotation above is updated on Nov 2021, and only for reference purposes. Please contact us for getting the latest Price, due to different weights in diverse product designs, timely changes in material cost and currency exchange rate, etc.
- 2) Regarding the material type, please refer to *Reference: Worldwide Equivalents Grades of Steel* on Page.53~57.
- 3) The (a~d) Unit Price without Tax.
- 4) If the product orders over 30,000 pieces, the Mould Fee will be returned after the contract is formally signed.

### TECHNICAL SPECIFICATION

For Concept Design & Mould Simulation:

- All dimensions including R angles can be appropriately adjusted according to technical requirements.
- The size of the tolerance can be adjusted according to the client needs.

For Production:

- The product physical performance and surface treatment meet the technical requirements of the drawings.
- The product must have NO burrs, NO crack, NO pits and NO other defects that affect product use.



## CONCEPT DESIGN

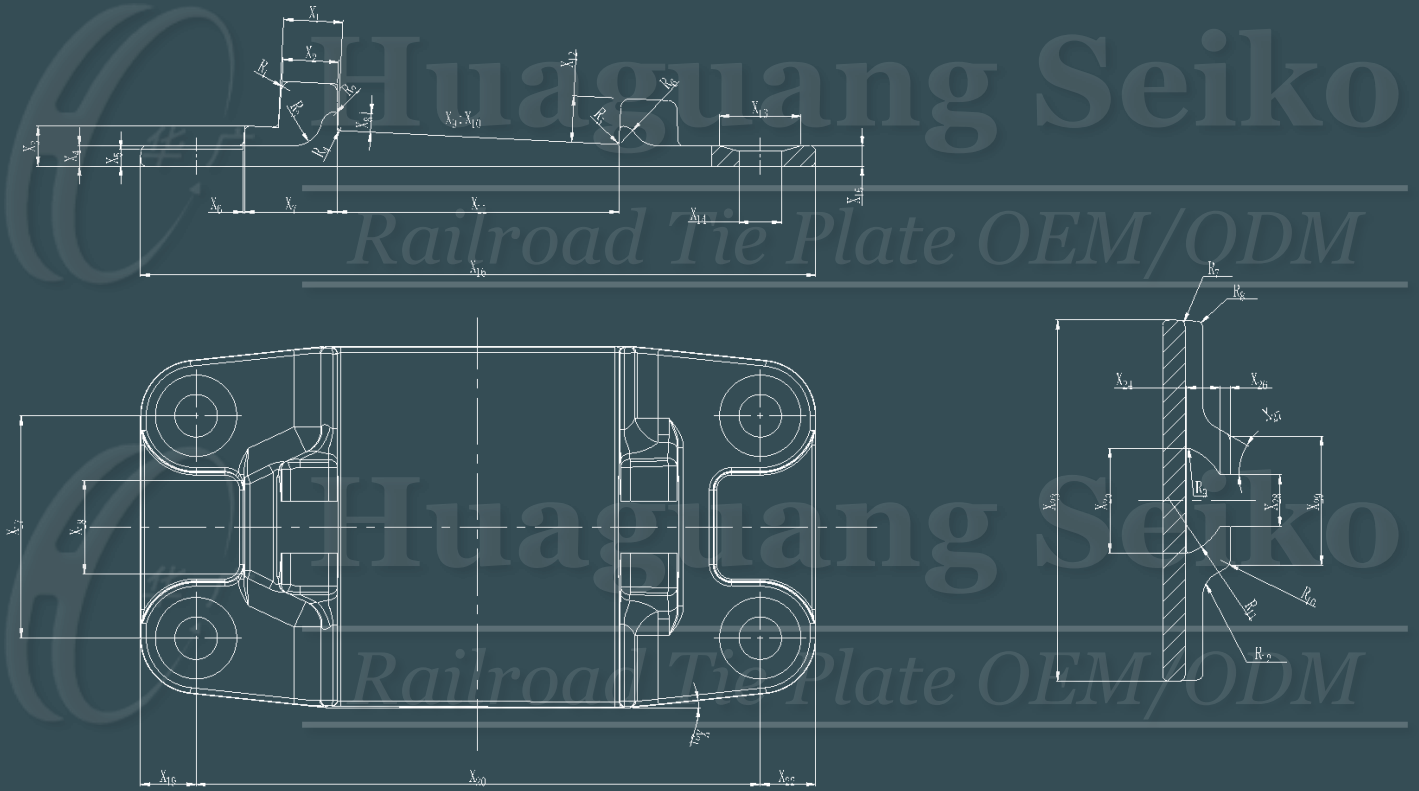

## MOULD SIMULATION



Note: In the interests of product improvement, Huaguang Seiko reserves the right to change the specifications contained herein at any time without prior notice.

## 15. Middle Eastern Standard Railway Type: MESR-4R

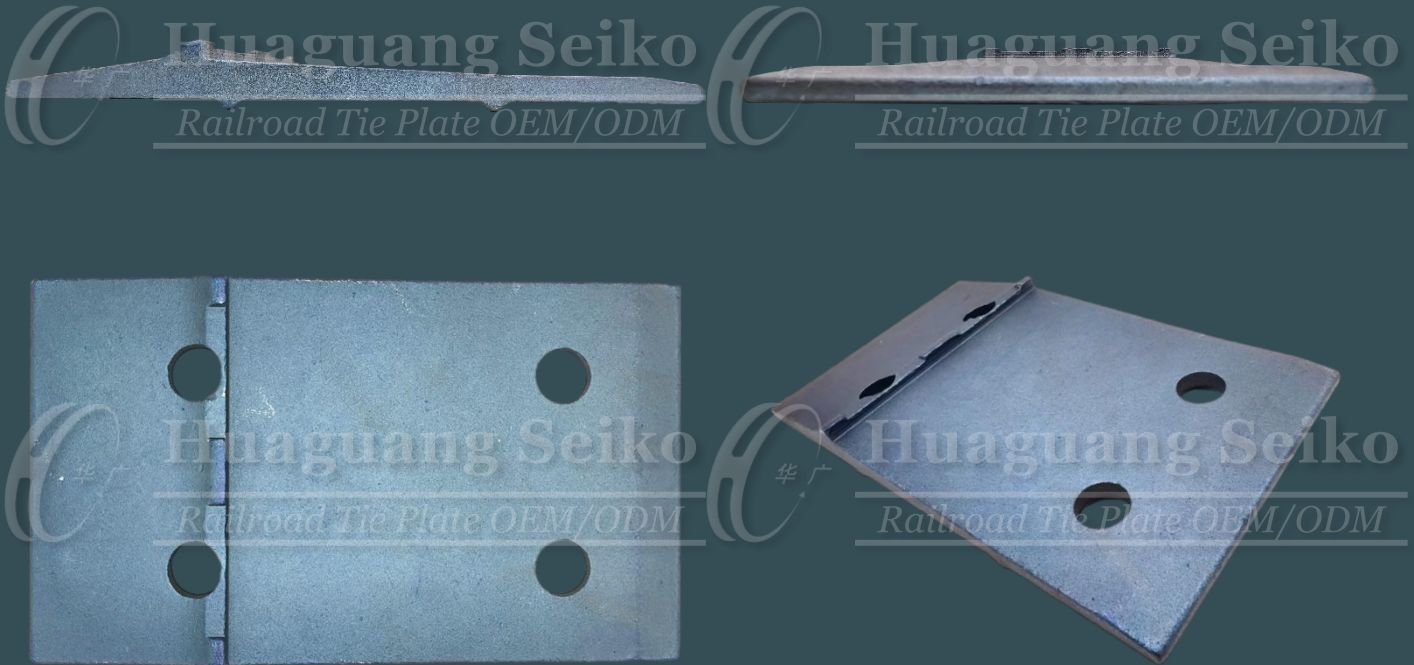

### QUOTATION<sup>(1)</sup>

Material Type <sup>(2)</sup>	Sample Product Weight	Material Weight
Can be required by client needs in different country standard	5.0 kg	6.2 kg

(a) Material Cost	(b) Production Cost	(c) Packaging Cost	(d) Delivery Cost	(a~d) Unit Price <sup>(3)</sup>	Mould Fee <sup>(4)</sup>
Depend on the steel grade	EUR €2.0/pc	EUR €0.2/pc	Depend on the country and location	EUR €2.2/pc + (a+d)	EUR €2,500

Note:

- 1) The Quotation above is updated on Nov 2021, and only for reference purposes. Please contact us for getting the latest Price, due to different weights in diverse product designs, timely changes in material cost and currency exchange rate, etc.
- 2) Regarding the material type, please refer to *Reference: Worldwide Equivalents Grades of Steel* on Page.53~57.
- 3) The (a~d) Unit Price without Tax.
- 4) If the product orders over 30,000 pieces, the Mould Fee will be returned after the contract is formally signed.

### TECHNICAL SPECIFICATION

For Concept Design & Mould Simulation:

- All dimensions including R angles can be appropriately adjusted according to technical requirements.
- The size of the tolerance can be adjusted according to the client needs.

For Production:

- The product physical performance and surface treatment meet the technical requirements of the drawings.
- The product must have NO burrs, NO crack, NO pits and NO other defects that affect product use.

## CONCEPT DESIGN

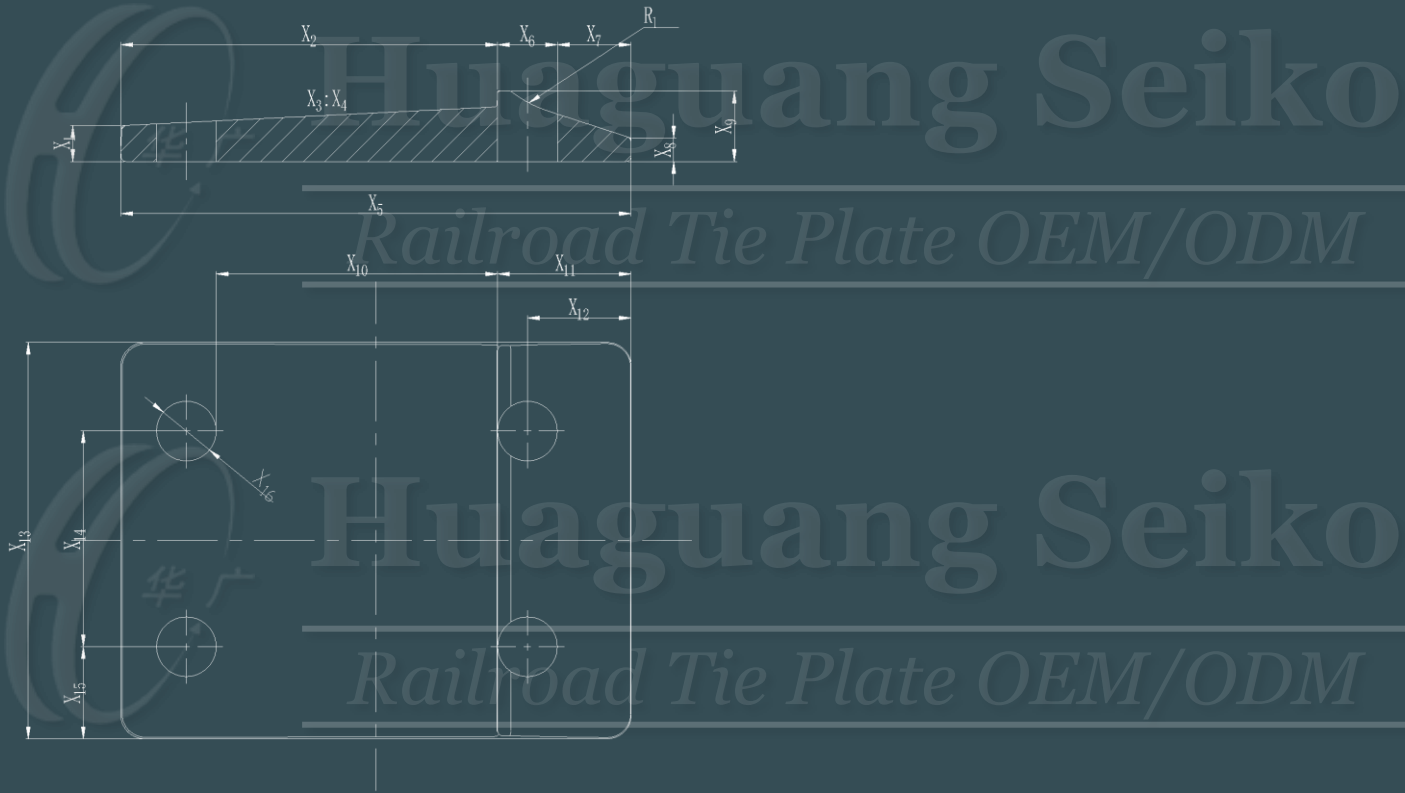

## MOULD SIMULATION



Note: In the interests of product improvement, Huaguang Seiko reserves the right to change the specifications contained herein at any time without prior notice.

## 16. ASEAN Standard Subway Type: ASS-2R



### QUOTATION<sup>(1)</sup>

Material Type <sup>(2)</sup>	Sample Product Weight	Material Weight
Can be required by client needs in different country standard	8.2 kg	9.7 kg

(a) Material Cost	(b) Production Cost	(c) Packaging Cost	(d) Delivery Cost	(a~d) Unit Price <sup>(3)</sup>	Mould Fee <sup>(4)</sup>
Depend on the steel grade	EUR €3.8/pc	EUR €0.2/pc	Depend on the country and location	EUR €4.0/pc + (a+d)	EUR €3,750

Note:

- 1) The Quotation above is updated on Nov 2021, and only for reference purposes. Please contact us for getting the latest Price, due to different weights in diverse product designs, timely changes in material cost and currency exchange rate, etc.
- 2) Regarding the material type, please refer to *Reference: Worldwide Equivalents Grades of Steel* on Page.53~57.
- 3) The (a~d) Unit Price without Tax.
- 4) If the product orders over 30,000 pieces, the Mould Fee will be returned after the contract is formally signed.

### TECHNICAL SPECIFICATION

For Concept Design & Mould Simulation:

- All dimensions including R angles can be appropriately adjusted according to technical requirements.
- The size of the tolerance can be adjusted according to the client needs.

For Production:

- The product physical performance and surface treatment meet the technical requirements of the drawings.
- The product must have NO burrs, NO crack, NO pits and NO other defects that affect product use.

## CONCEPT DESIGN

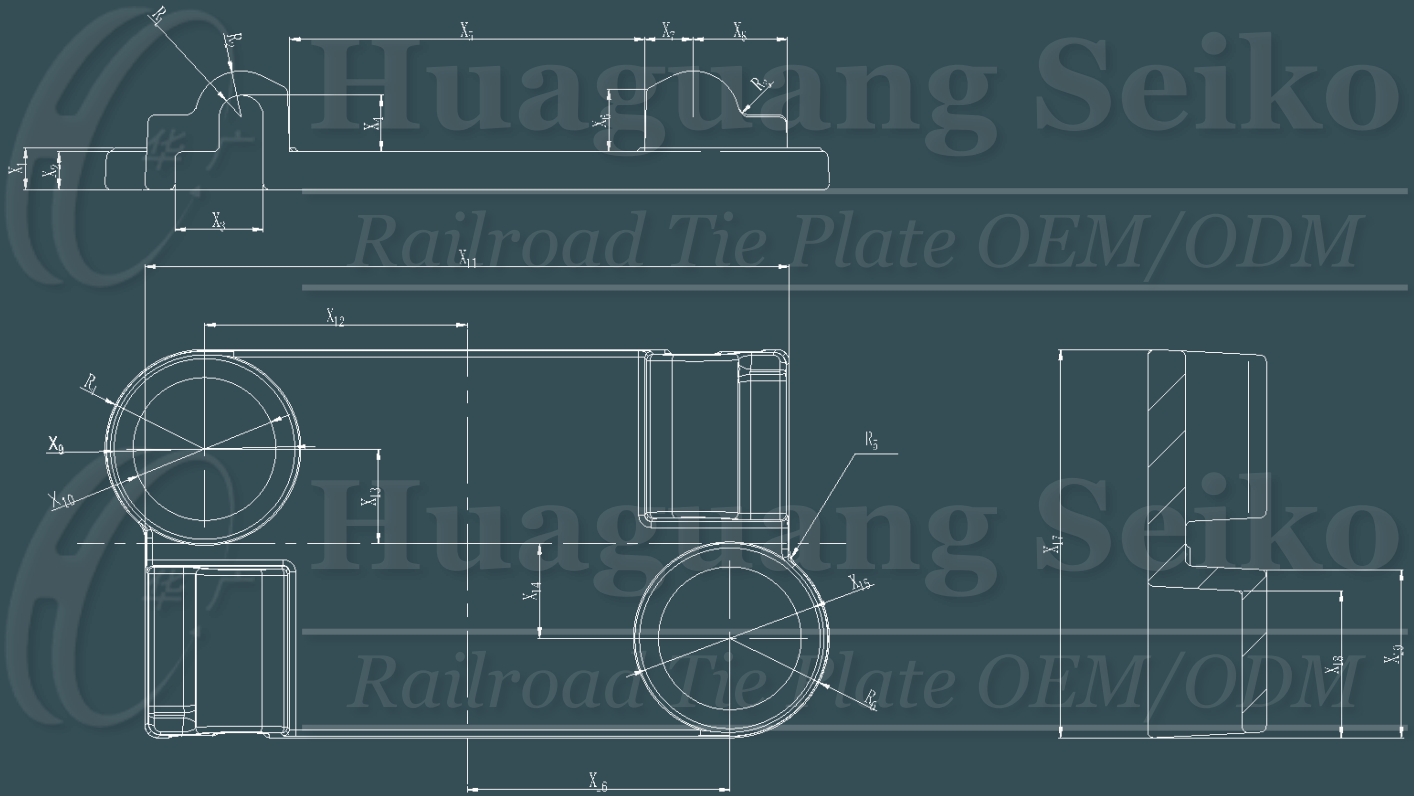

## MOULD SIMULATION



Note: In the interests of product improvement, Huaguang Seiko reserves the right to change the specifications contained herein at any time without prior notice.

## 17. ASEAN Standard Subway Type: ASS-4R

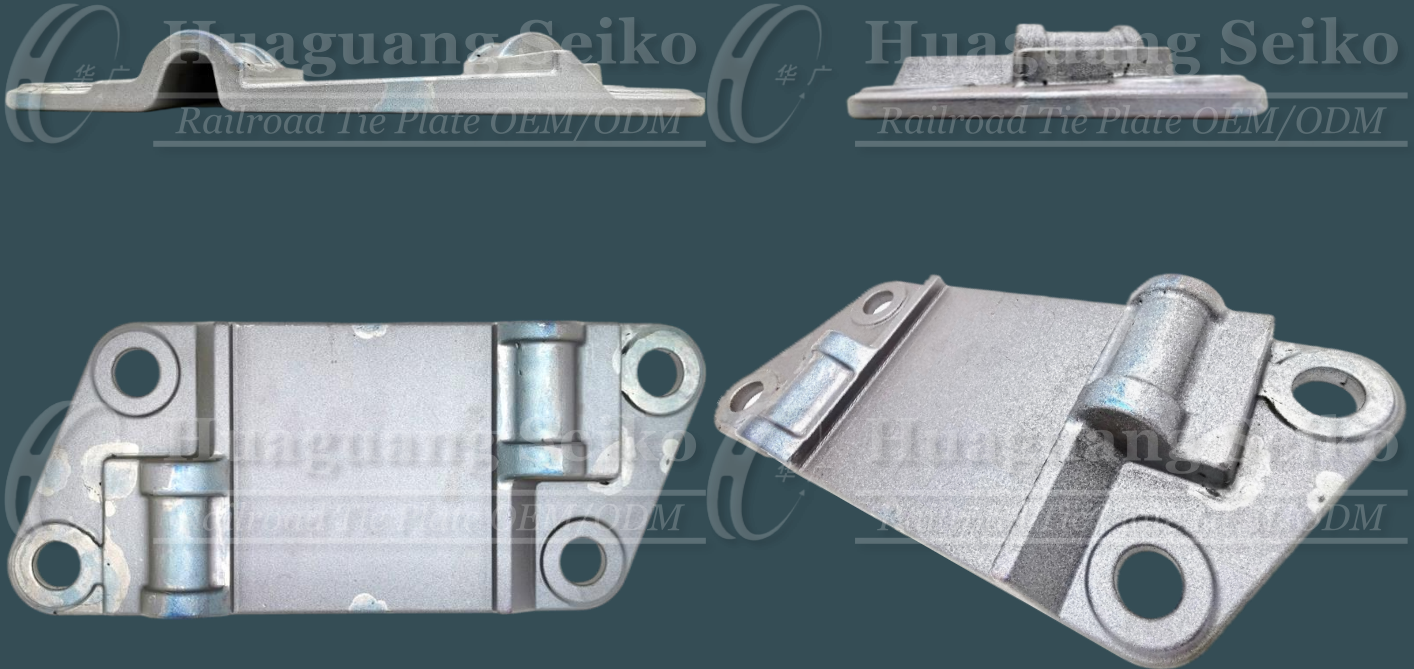

### QUOTATION<sup>(1)</sup>

Material Type <sup>(2)</sup>	Sample Product Weight	Material Weight
Can be required by client needs in different country standard	8.8 kg	10.3 kg

(a) Material Cost	(b) Production Cost	(c) Packaging Cost	(d) Delivery Cost	(a~d) Unit Price <sup>(3)</sup>	Mould Fee <sup>(4)</sup>
Depend on the steel grade	EUR €4.2/pc	EUR €0.2/pc	Depend on the country and location	EUR €4.4/pc + (a+d)	EUR €3,500

Note:

- 1) The Quotation above is updated on Nov 2021, and only for reference purposes. Please contact us for getting the latest Price, due to different weights in diverse product designs, timely changes in material cost and currency exchange rate, etc.
- 2) Regarding the material type, please refer to *Reference: Worldwide Equivalents Grades of Steel* on Page.53~57.
- 3) The (a~d) Unit Price without Tax.
- 4) If the product orders over 30,000 pieces, the Mould Fee will be returned after the contract is formally signed.

### TECHNICAL SPECIFICATION

For Concept Design & Mould Simulation:

- All dimensions including R angles can be appropriately adjusted according to technical requirements.
- The size of the tolerance can be adjusted according to the client needs.

For Production:

- The product physical performance and surface treatment meet the technical requirements of the drawings.
- The product must have NO burrs, NO crack, NO pits and NO other defects that affect product use.

## CONCEPT DESIGN

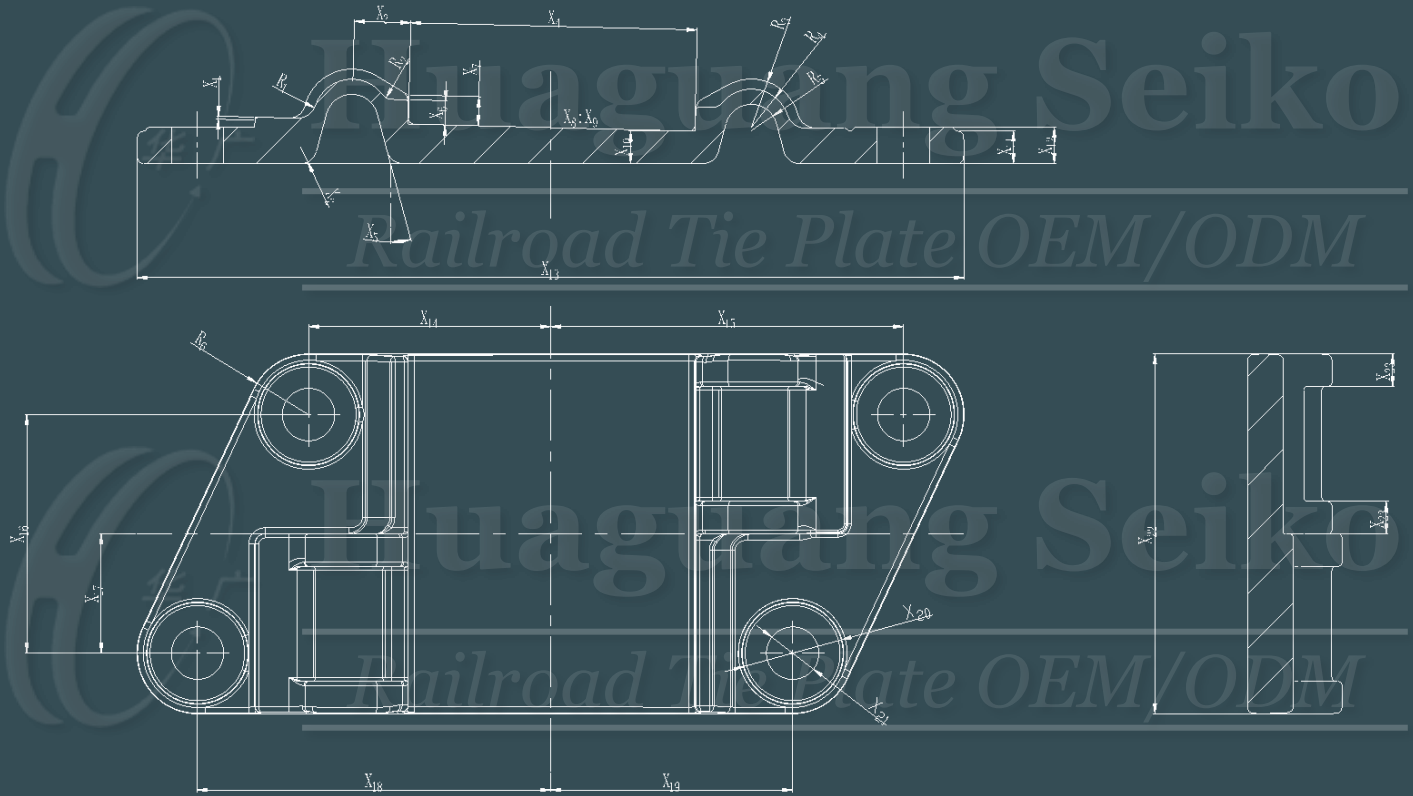

## MOULD SIMULATION



Note: In the interests of product improvement, Huaguang Seiko reserves the right to change the specifications contained herein at any time without prior notice.

## 18. ASEAN Standard Subway Type: ASR-20



### QUOTATION<sup>(1)</sup>

Material Type <sup>(2)</sup>	Sample Product Weight	Material Weight
Can be required by client needs in different country standard	7.8 kg	9.1 kg

(a) Material Cost	(b) Production Cost	(c) Packaging Cost	(d) Delivery Cost	(a~d) Unit Price <sup>(3)</sup>	Mould Fee <sup>(4)</sup>
Depend on the steel grade	EUR €3.7/pc	EUR €0.2/pc	Depend on the country and location	EUR €3.9/pc + (a+d)	EUR €3,250

Note:

- 1) The Quotation above is updated on Nov 2021, and only for reference purposes. Please contact us for getting the latest Price, due to different weights in diverse product designs, timely changes in material cost and currency exchange rate, etc.
- 2) Regarding the material type, please refer to *Reference: Worldwide Equivalents Grades of Steel* on Page.53~57.
- 3) The (a~d) Unit Price without Tax.
- 4) If the product orders over 30,000 pieces, the Mould Fee will be returned after the contract is formally signed.

### TECHNICAL SPECIFICATION

For Concept Design & Mould Simulation:

- All dimensions including R angles can be appropriately adjusted according to technical requirements.
- The size of the tolerance can be adjusted according to the client needs.

For Production:

- The product physical performance and surface treatment meet the technical requirements of the drawings.
- The product must have NO burrs, NO crack, NO pits and NO other defects that affect product use.



## CONCEPT DESIGN

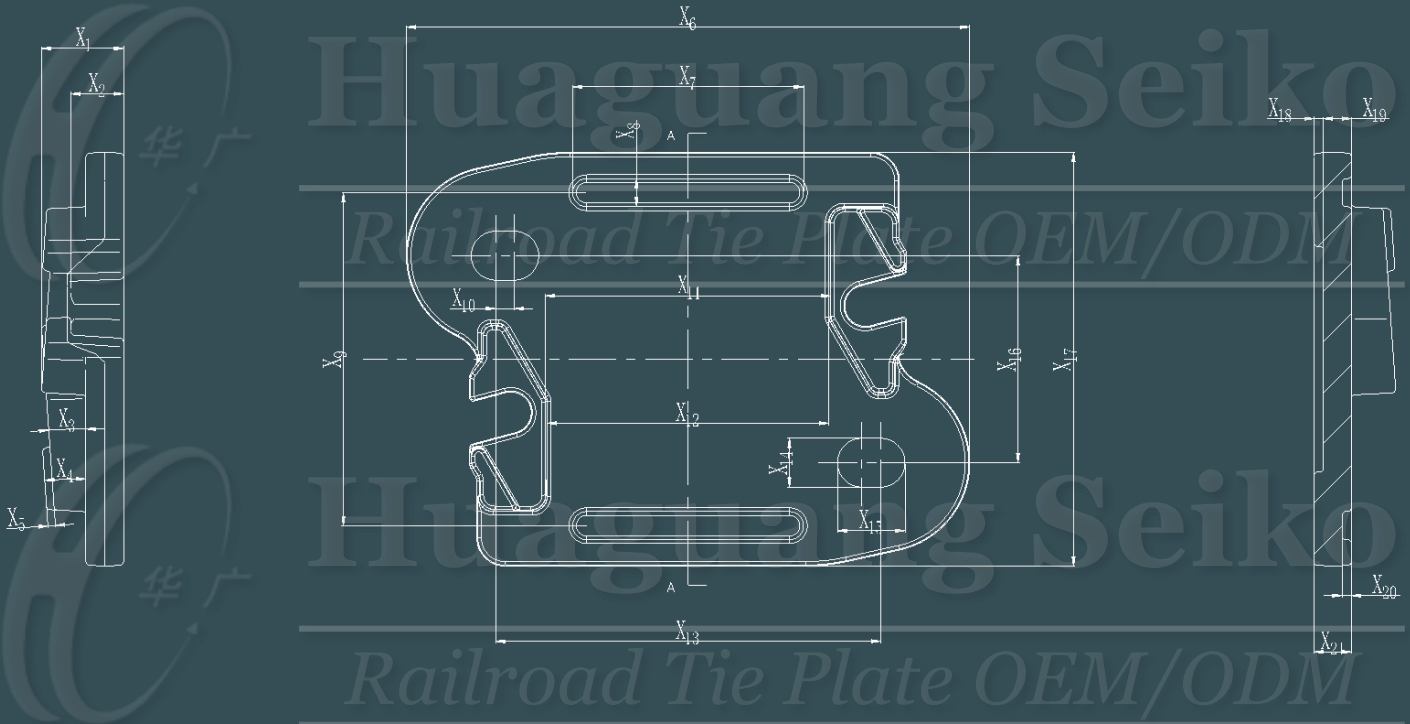

## MOULD SIMULATION



Note: In the interests of product improvement, Huaguang Seiko reserves the right to change the specifications contained herein at any time without prior notice.

## 19. ASEAN Standard Railway Type: ASR-4R

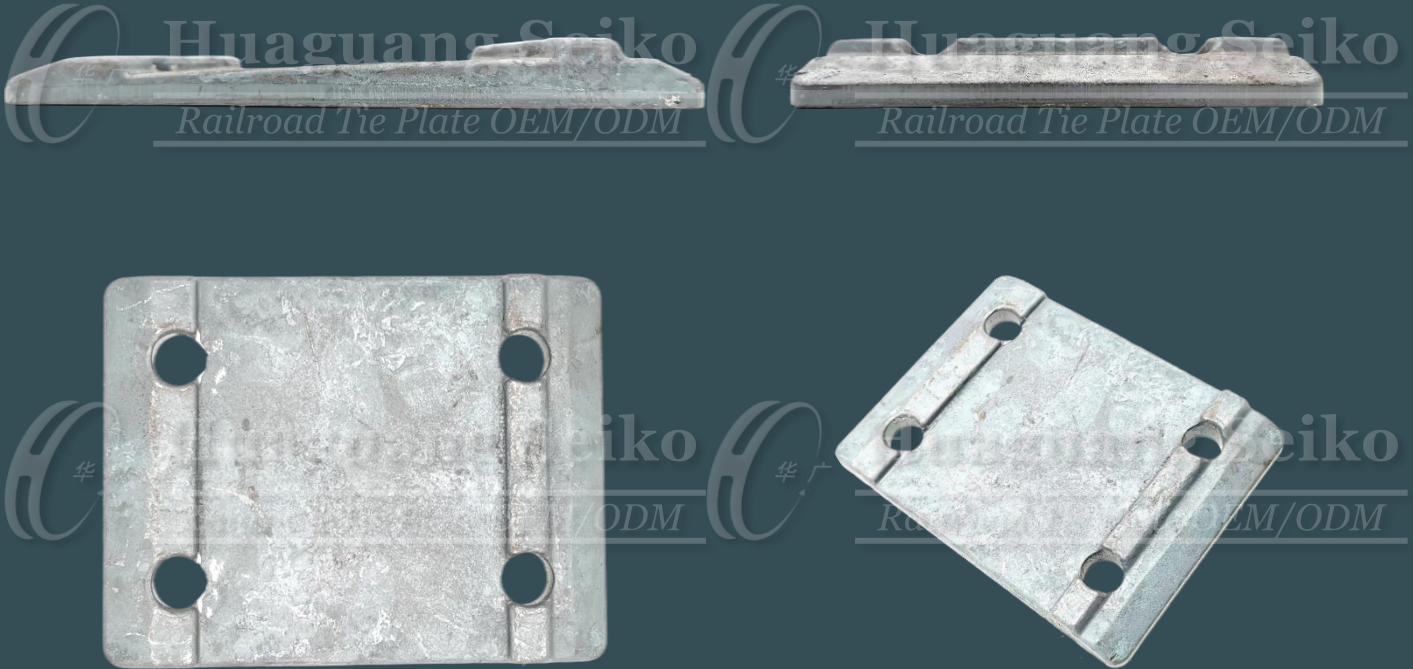

### QUOTATION<sup>(1)</sup>

Material Type <sup>(2)</sup>	Sample Product Weight	Material Weight
Can be required by client needs in different country standard	4.6 kg	5.6 kg

(a) Material Cost	(b) Production Cost	(c) Packaging Cost	(d) Delivery Cost	(a~d) Unit Price <sup>(3)</sup>	Mould Fee <sup>(4)</sup>
Depend on the steel grade	EUR €2.0/pc	EUR €0.1/pc	Depend on the country and location	EUR €2.1/pc + (a+d)	EUR €2,500

Note:

- 1) The Quotation above is updated on Nov 2021, and only for reference purposes. Please contact us for getting the latest Price, due to different weights in diverse product designs, timely changes in material cost and currency exchange rate, etc.
- 2) Regarding the material type, please refer to *Reference: Worldwide Equivalents Grades of Steel* on Page.53~57.
- 3) The (a~d) Unit Price without Tax.
- 4) If the product orders over 30,000 pieces, the Mould Fee will be returned after the contract is formally signed.

### TECHNICAL SPECIFICATION

For Concept Design & Mould Simulation:

- All dimensions including R angles can be appropriately adjusted according to technical requirements.
- The size of the tolerance can be adjusted according to the client needs.

For Production:

- The product physical performance and surface treatment meet the technical requirements of the drawings.
- The product must have NO burrs, NO crack, NO pits and NO other defects that affect product use.

## CONCEPT DESIGN

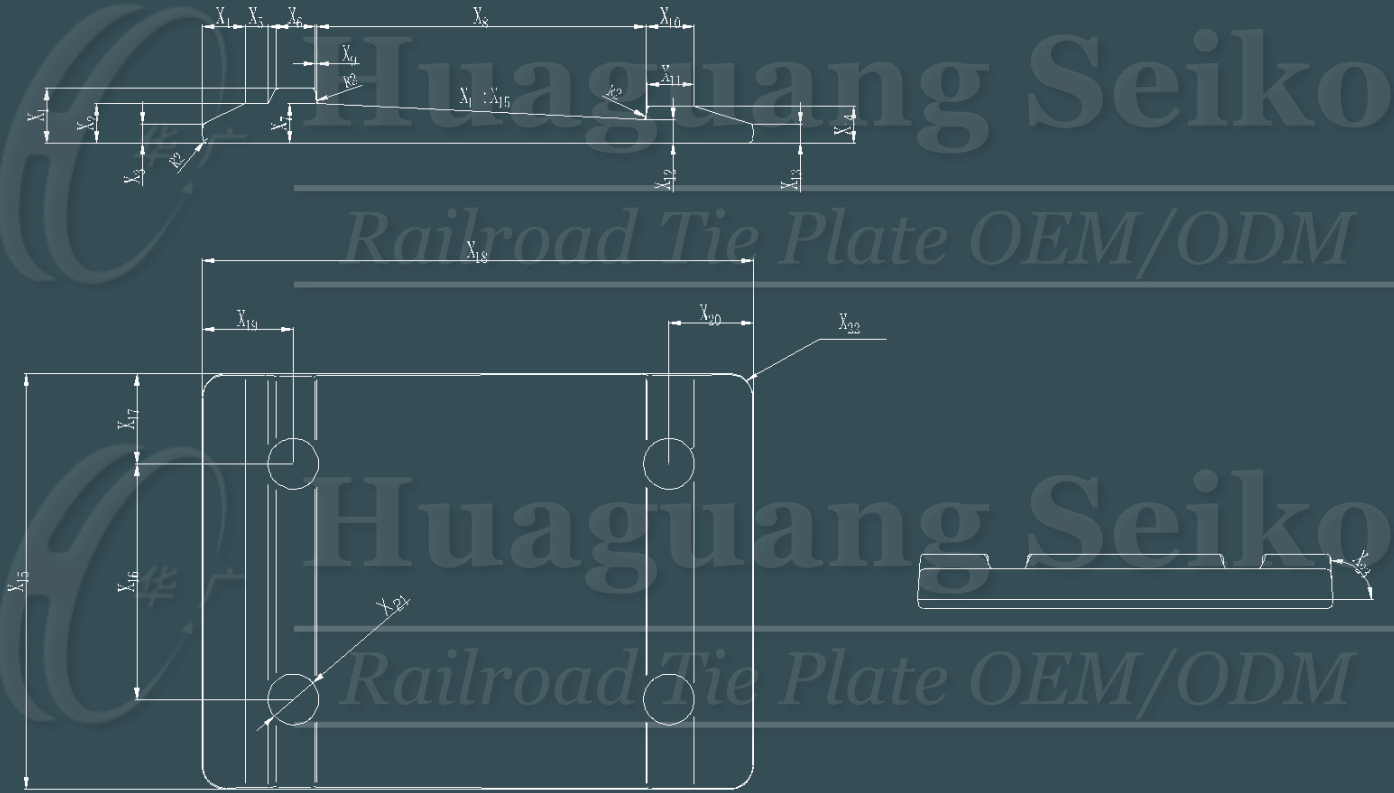

## MOULD SIMULATION



Note: In the interests of product improvement, Huaguang Seiko reserves the right to change the specifications contained herein at any time without prior notice.

## 20. Oceanian High-speed Railway Type: OHR-4R



### QUOTATION<sup>(1)</sup>

Material Type <sup>(2)</sup>	Sample Product Weight	Material Weight
Can be required by client needs in different country standard	12.0 kg	13.4 kg

(a) Material Cost	(b) Production Cost	(c) Packaging Cost	(d) Delivery Cost	(a~d) Unit Price <sup>(3)</sup>	Mould Fee <sup>(4)</sup>
Depend on the steel grade	EUR €6.2/pc	EUR €0.3/pc	Depend on the country and location	EUR €6.5/pc + (a+d)	EUR €4,250

Note:

- 1) The Quotation above is updated on Nov 2021, and only for reference purposes. Please contact us for getting the latest Price, due to different weights in diverse product designs, timely changes in material cost and currency exchange rate, etc.
- 2) Regarding the material type, please refer to *Reference: Worldwide Equivalents Grades of Steel* on Page.53~57.
- 3) The (a~d) Unit Price without Tax.
- 4) If the product orders over 30,000 pieces, the Mould Fee will be returned after the contract is formally signed.

### TECHNICAL SPECIFICATION

For Concept Design & Mould Simulation:

- All dimensions including R angles can be appropriately adjusted according to technical requirements.
- The size of the tolerance can be adjusted according to the client needs.

For Production:

- The product physical performance and surface treatment meet the technical requirements of the drawings.
- The product must have NO burrs, NO crack, NO pits and NO other defects that affect product use.

## CONCEPT DESIGN

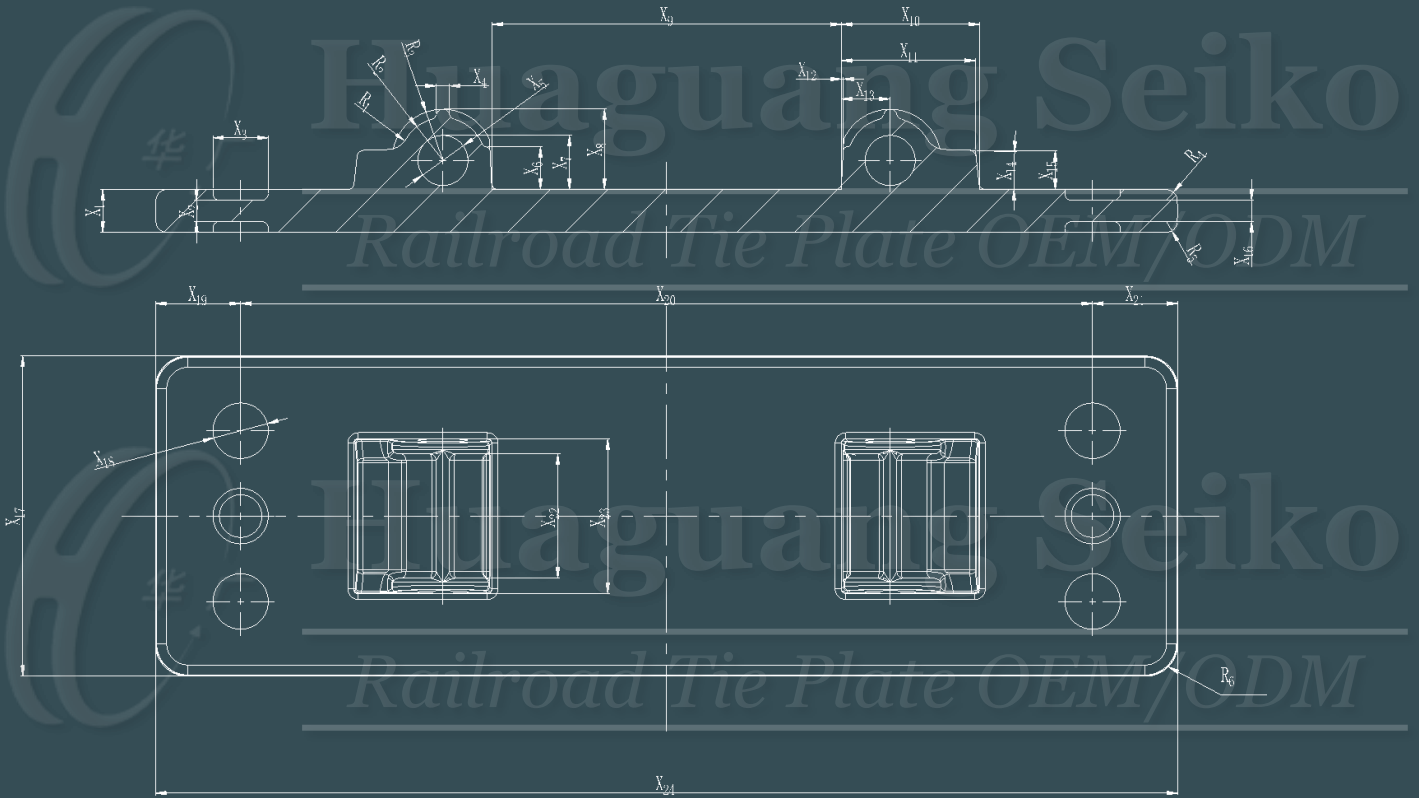

## MOULD SIMULATION



Note: In the interests of product improvement, Huaguang Seiko reserves the right to change the specifications contained herein at any time without prior notice.

## 21. Oceanian High-speed Railway Type: OHR-40



### QUOTATION<sup>(1)</sup>

Material Type <sup>(2)</sup>	Sample Product Weight	Material Weight
Can be required by client needs in different country standard	16.5 kg	18.3 kg

(a) Material Cost	(b) Production Cost	(c) Packaging Cost	(d) Delivery Cost	(a~d) Unit Price <sup>(3)</sup>	Mould Fee <sup>(4)</sup>
Depend on the steel grade	EUR €8.7/pc	EUR €0.3/pc	Depend on the country and location	EUR €9.0/pc + (a+d)	EUR €4,750

Note:

- 1) The Quotation above is updated on Nov 2021, and only for reference purposes. Please contact us for getting the latest Price, due to different weights in diverse product designs, timely changes in material cost and currency exchange rate, etc.
- 2) Regarding the material type, please refer to *Reference: Worldwide Equivalents Grades of Steel* on Page.53~57.
- 3) The (a~d) Unit Price without Tax.
- 4) If the product orders over 30,000 pieces, the Mould Fee will be returned after the contract is formally signed.

### TECHNICAL SPECIFICATION

For Concept Design & Mould Simulation:

- All dimensions including R angles can be appropriately adjusted according to technical requirements.
- The size of the tolerance can be adjusted according to the client needs.

For Production:

- The product physical performance and surface treatment meet the technical requirements of the drawings.
- The product must have NO burrs, NO crack, NO pits and NO other defects that affect product use.

## CONCEPT DESIGN

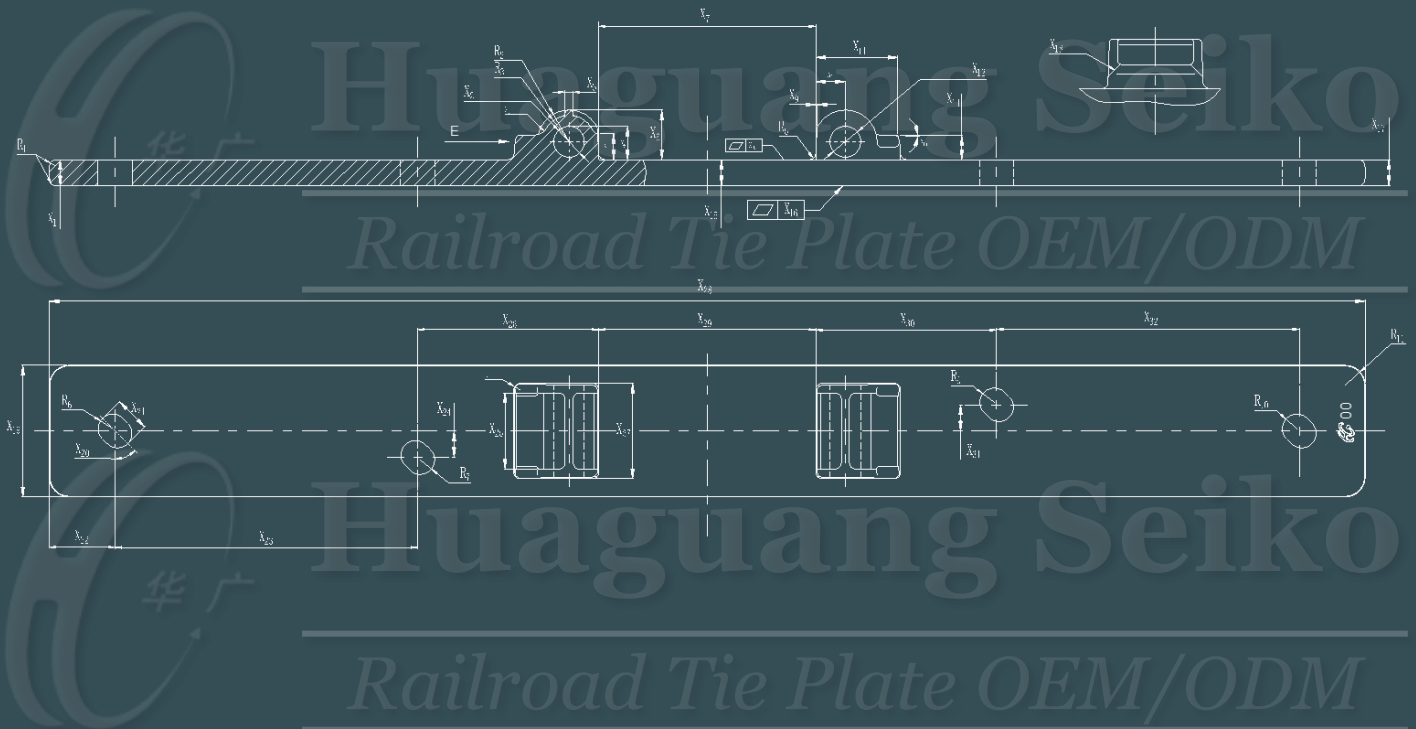

## MOULD SIMULATION



Note: In the interests of product improvement, Huaguang Seiko reserves the right to change the specifications contained herein at any time without prior notice.

## 22. Rail Anchor Standard Type



### QUOTATION<sup>(1)</sup>

Material Type <sup>(2)</sup>	Sample Product Weight	Material Weight
Can be required by client needs in different country standard	1.3 kg	1.5 kg

(a) Material Cost	(b) Production Cost	(c) Packaging Cost	(d) Delivery Cost	(a~d) Unit Price <sup>(3)</sup>	Mould Fee <sup>(4)</sup>
Depend on the steel grade	EUR €0.6/pc	EUR €0.1/pc	Depend on the country and location	EUR €0.7/pc + (a+d)	EUR €2,000

Note:

- 1) The Quotation above is updated on Nov 2021, and only for reference purposes. Please contact us for getting the latest Price, due to different weights in diverse product designs, timely changes in material cost and currency exchange rate, etc.
- 2) Regarding the material type, please refer to *Reference: Worldwide Equivalents Grades of Steel* on Page.53~57.
- 3) The (a~d) Unit Price without Tax.
- 4) If the product orders over 30,000 pieces, the Mould Fee will be returned after the contract is formally signed.

### TECHNICAL SPECIFICATION

For Concept Design & Mould Simulation:

- All dimensions including R angles can be appropriately adjusted according to technical requirements.
- The size of the tolerance can be adjusted according to the client needs.

For Production:

- The product physical performance and surface treatment meet the technical requirements of the drawings.
- The product must have NO burrs, NO crack, NO pits and NO other defects that affect product use.



## CONCEPT DESIGN

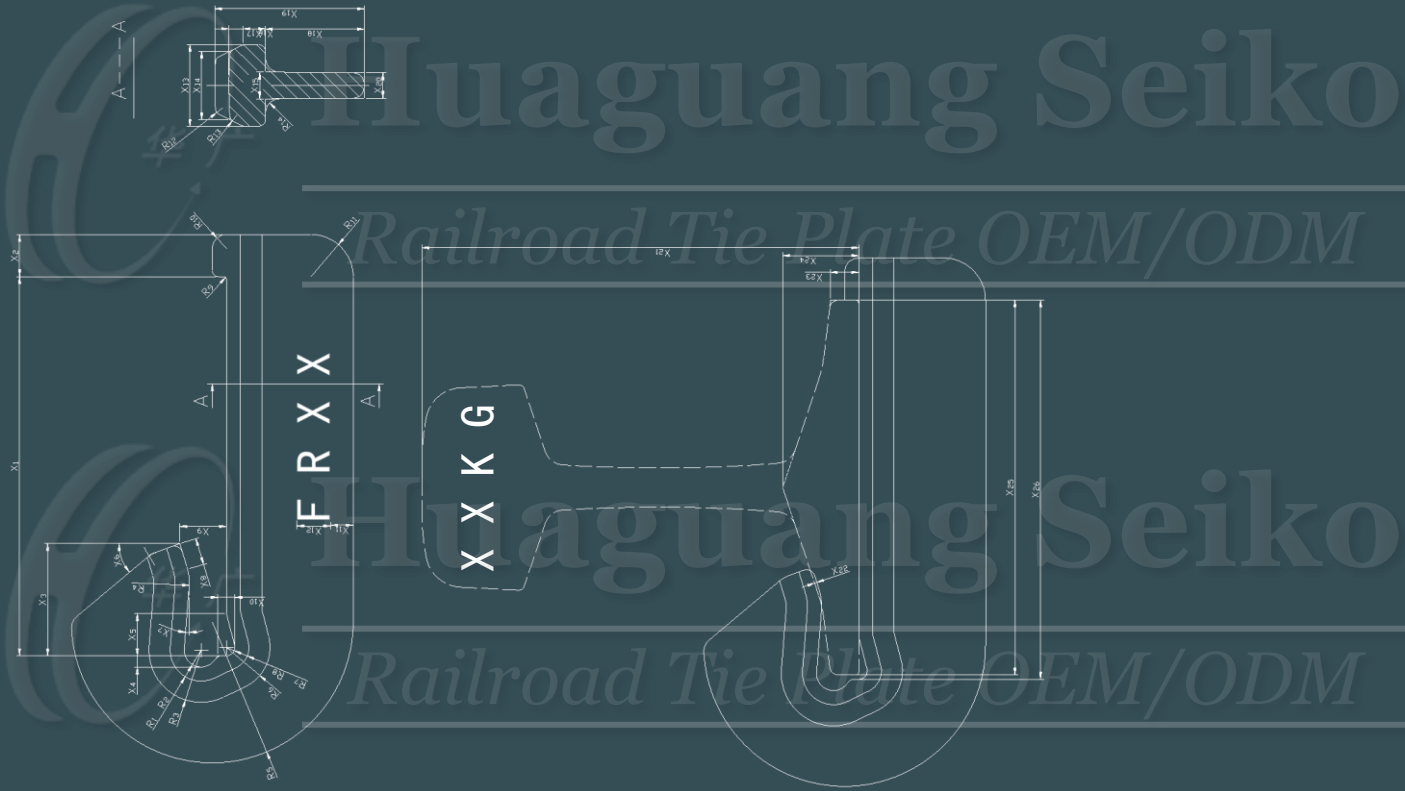

## MOULD SIMULATION



Note: In the interests of product improvement, Huaguang Seiko reserves the right to change the specifications contained herein at any time without prior notice.

## 23. Fishplate Standard Type

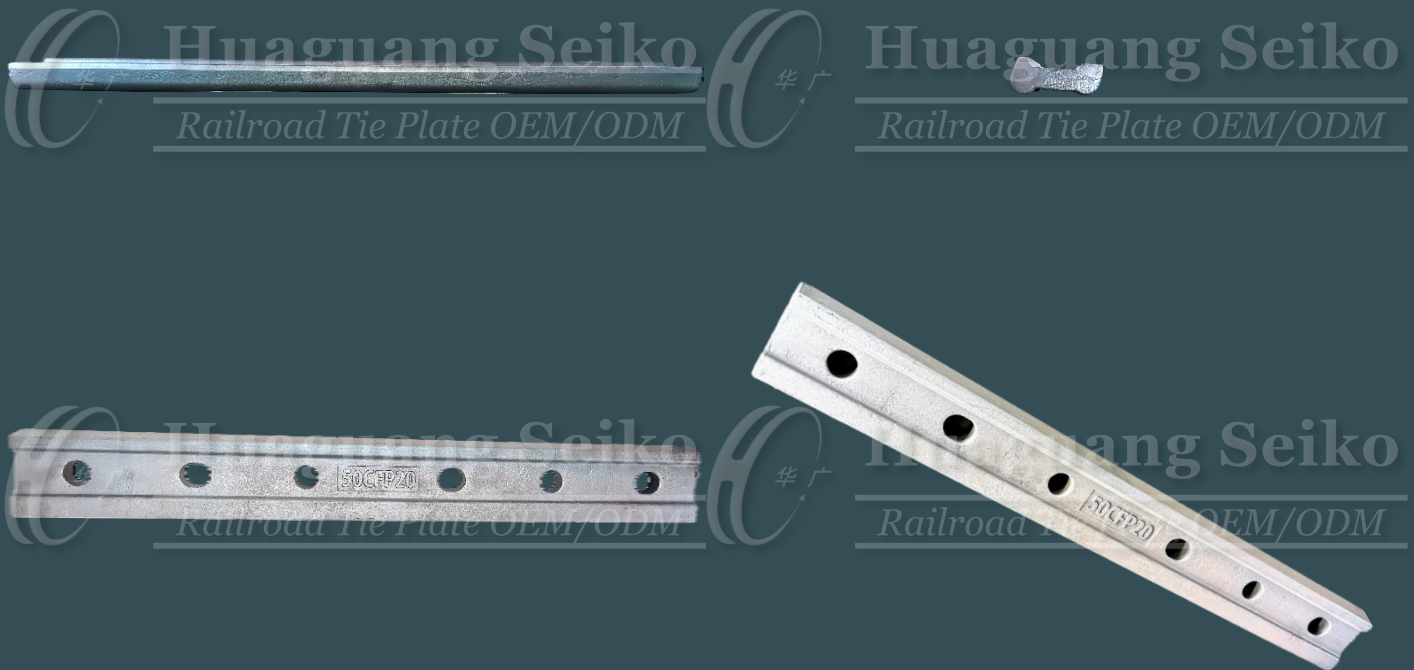

### QUOTATION<sup>(1)</sup>

Material Type <sup>(2)</sup>	Sample Product Weight	Material Weight
Can be required by client needs in different country standard	16.1 kg	18.0 kg

(a) Material Cost	(b) Production Cost	(c) Packaging Cost	(d) Delivery Cost	(a~d) Unit Price <sup>(3)</sup>	Mould Fee <sup>(4)</sup>
Depend on the steel grade	EUR €8.4/pc	EUR €0.3/pc	Depend on the country and location	EUR €8.7/pc + (a+d)	EUR €4,750

Note:

- 1) The Quotation above is updated on Nov 2021, and only for reference purposes. Please contact us for getting the latest Price, due to different weights in diverse product designs, timely changes in material cost and currency exchange rate, etc.
- 2) Regarding the material type, please refer to *Reference: Worldwide Equivalents Grades of Steel* on Page.53~57.
- 3) The (a~d) Unit Price without Tax.
- 4) If the product orders over 30,000 pieces, the Mould Fee will be returned after the contract is formally signed.

### TECHNICAL SPECIFICATION

For Concept Design & Mould Simulation:

- All dimensions including R angles can be appropriately adjusted according to technical requirements.
- The size of the tolerance can be adjusted according to the client needs.

For Production:

- The product physical performance and surface treatment meet the technical requirements of the drawings.
- The product must have NO burrs, NO crack, NO pits and NO other defects that affect product use.

## CONCEPT DESIGN

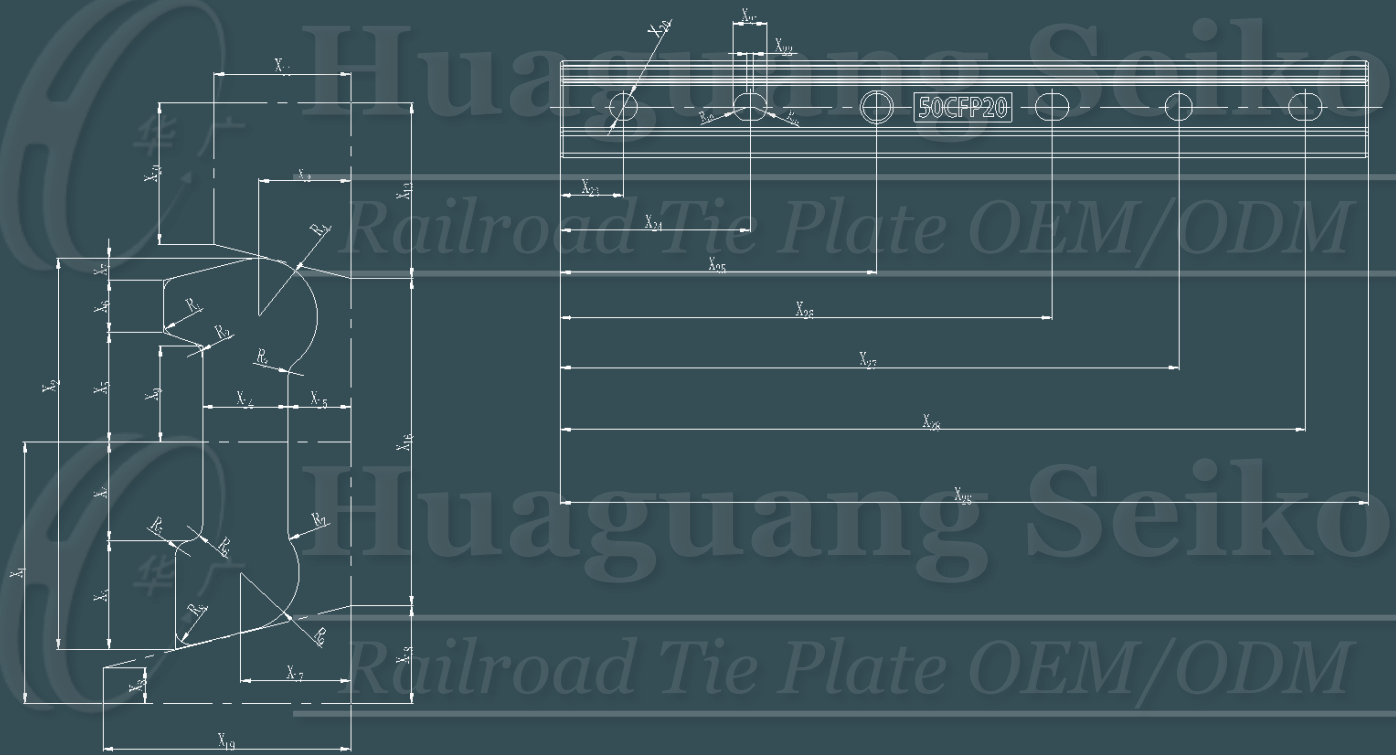

## MOULD SIMULATION



Note: In the interests of product improvement, Huaguang Seiko reserves the right to change the specifications contained herein at any time without prior notice.

## 24. Fishplate Special Type



### QUOTATION<sup>(1)</sup>

Material Type <sup>(2)</sup>	Sample Product Weight	Material Weight
Can be required by client needs in different country standard	8.6 kg	10.1 kg

(a) Material Cost	(b) Production Cost	(c) Packaging Cost	(d) Delivery Cost	(a~d) Unit Price <sup>(3)</sup>	Mould Fee <sup>(4)</sup>
Depend on the steel grade	EUR €4.1/pc	EUR €0.2/pc	Depend on the country and location	EUR €4.3/pc + (a+d)	EUR €3,500

Note:

- 1) The Quotation above is updated on Nov 2021, and only for reference purposes. Please contact us for getting the latest Price, due to different weights in diverse product designs, timely changes in material cost and currency exchange rate, etc.
- 2) Regarding the material type, please refer to *Reference: Worldwide Equivalents Grades of Steel* on Page.53~57.
- 3) The (a~d) Unit Price without Tax.
- 4) If the product orders over 30,000 pieces, the Mould Fee will be returned after the contract is formally signed.

### TECHNICAL SPECIFICATION

For Concept Design & Mould Simulation:

- All dimensions including R angles can be appropriately adjusted according to technical requirements.
- The size of the tolerance can be adjusted according to the client needs.

For Production:

- The product physical performance and surface treatment meet the technical requirements of the drawings.
- The product must have NO burrs, NO crack, NO pits and NO other defects that affect product use.

## CONCEPT DESIGN



## MOULD SIMULATION

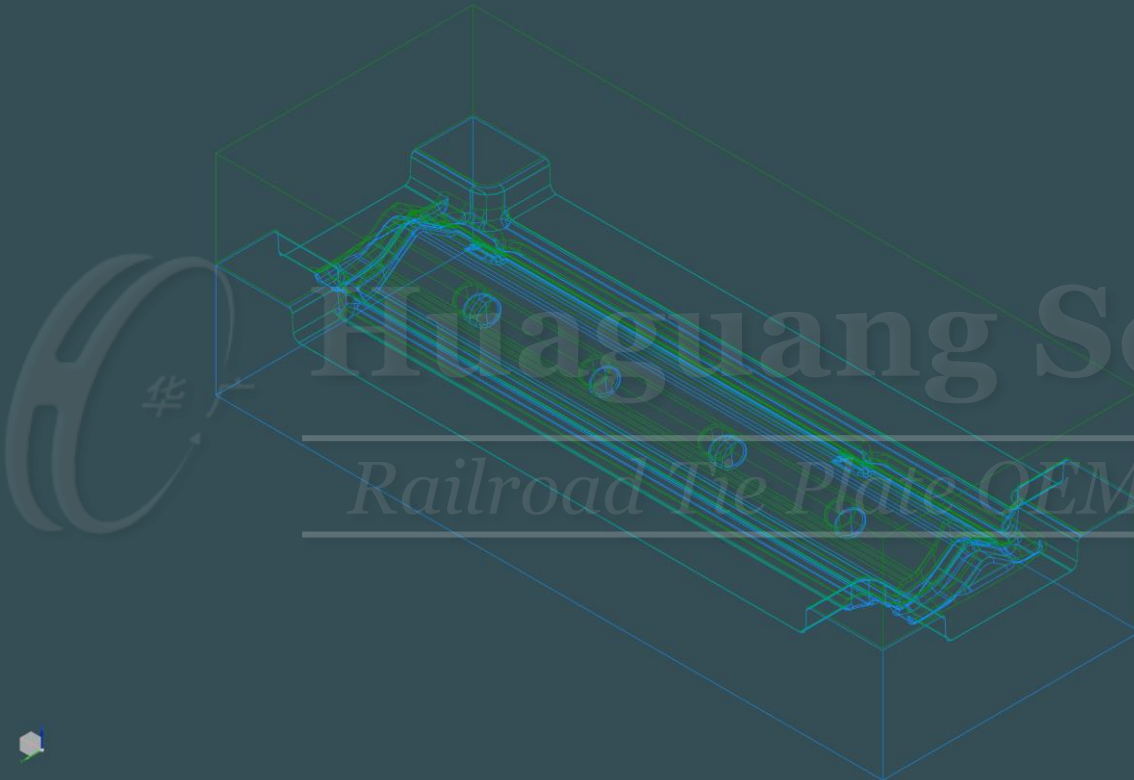

Note: In the interests of product improvement, Huaguang Seiko reserves the right to change the specifications contained herein at any time without prior notice.

## Reference: Worldwide Equivalents Grades of Steel for Int. & EU

#	International ISO	EU EN	USA AISI, ASTM, UNS	Germany DIN, WNr	Japan JIS	France AFNOR	England BS	China GB	Russia GOST
1	15NiCr13	15NiCr13 (1.5752)					655M13		
2	16MnCr5	16MnCr5 (1.7131)	SAE5115	16MnCr5		16MC5	527M17 590M17	15CrMn 16MnCr 20CrMnTi	18KHG
3	16MnCrS5	16MnCrS5 (1.7139)		16MnCrS5		16MC5			
4	17NiCrMo6	17NiCrMo6-4 (1.6566)				18NCD6	815M17		
5	18CrMo4	18CrMo4 (1.7243)		18CrMo4	SCM418	18CD4 18CrMo4	708H20 708M20		20KHM
6	18CrMoS4	18CrMoS4 (1.7244)							
7	18CrNiMo7	18CrNiMo7-6 (1.6587)		17CrNiMo6 17CrNiMo7		18NCD6	820A16	17Cr2Ni2Mo	
8	20-40	C18D (1.0416)	Gr.N1	G538	SC37	20-40M	AM1		15L
9	20MnCr5	20MnCr5 (1.7147)	SAE5120	20MnCr5	SMnC420H	20MC5		20CrMn 20CrMnTi 20MnCr	18KHG
10	20MnCrS5	20MnCrS5 (1.7149)							
11	20NiCrMo2	20NiCrMo2-2 (1.6523)		21NiCrMo2		20NCD2	805M20		20KHGNM
12	20NiCrMoS2	20NiCrMoS2-2 (1.6526)		20NiCrMoS2					
13	25CrMo4	25CrMo4 (1.7218)	SAE4130	25CrMo4	SCM420 SCM430	25CD4	708A25 708M25 CFS10	30CrMo	20KHM 30KHM 30KHMA
14	25CrMoS4	25CrMoS4 (1.7213)		25CrMoS4		25CD4u			
15	28Mn6	28Mn6 (1.1170)	1527 Gr.1330	28Mn6	SCMn2	35Mn5	120M36 150H19 150M19 150M28	30Mn2	30G 30G2
16	31CrNiMo8	30CrNiMo8 (1.6580)		30CrNiMo8	SNCM431	30CND8	823M30	30Cr2Ni2Mo	3KH3M3F
17	32CrMoV12-28	32CrMoV12-28 (1.2365)	H10	X32CrMoV3-3	SKD7	32CDV12-28	BH10		3KH3M3F
18	34Cr4	34Cr4 (1.7033)		34Cr4	Scr430H	32C4	530H32 530M32		30KH 35KH
19	34CrMo4	34CrMo4 (1.7220)	4135	34CrMo4	SCM435H	34CD4 35CD4	708A30 708M32	35CrMo ZG35CrMo	35KHM 35KHML
20	34CrMoS4	34CrMoS4 (1.7226)	4135	34CrMoS4		34CD4u			
21	34CrS4	34CrS4 (1.7037)		34CrS4		32C4u			
22	35S20	35S20 (1.0726)	1140	35S20		35MF6	212M36	Y35	
23	36CrNiMo4	36CrNiMo4 (1.6511)	Gr.9840	36CrNiMo4	SCNM439	40NCD3	817A37 817M37		40KHN2MA
24	36CrNiMo6	34CrNiMo6 (1.6582)	4340	34CrNiMo6 GS-34CrNiMo6V	SNCM447	35NCD6	817M40	34CrNi3Mo 34CrNiMo ZG34CrNiMo	36KH2N2MFA 38KH2N2MA 40KHN2MA
25	37Cr4	37Cr4 (1.7034)	Gr.5135	37Cr4	Scr435H	37Cr4 38C4	530A36 530M36	35Cr	38KHA 40KH
26	37CrS4	37CrS4 (1.7038)		37CrS4		38C4u			
27	41Cr4	41Cr4 (1.7035)		41Cr4	Scr440H	42C4	530M40		40KH 45KH 50
28	41CrS4	41CrS4 (1.7039)		41CrS4		42C4u			40KH
29	42CrMo4	42CrMo4 (1.7225)	4140 4142	42CrMo4	SCM440H	42CD4	708M40 CFS11	42CrMo	35KHM 38KHM
30	42CrMoS4	42CrMoS4 (1.7227)	4140	42CrMoS4		42CD4u			
31	44SMn28	44SMn28 (1.0762)						Y40Mn	A40G
32	46S20	46S20 (1.0727)		45S20					
33	50CrMo4	50CrMo4 (1.7228)		50CrMo4			708M40 708M50	50CrMo	
34	51CrV4	51CrV4 (1.8159)	6150	50CrV4	SUP10	50CrV4 50CV4 51CrV4	735A50 735A51	50CrVA	50KHGFA
35	55NiCrMoV7	55NiCrMoV7 (1.2714)	L6	55NiCrMoV6 56NiCrMoV7	SKT4	55NCDV7	BH224-5	5CrNiMo	5KHNM 5KHNV
36	60WCrV8	60WCrV8 (1.2550)	S1	60WCrV7		55WC20	BS1	6CrW2Si	5KHV2S
37	90MnCrV8	90MnCrV8 (1.2842)	2	90MnCrV8		90MnV8	B02		

#	International ISO	EU EN	USA AISI, ASTM, UNS	Germany DIN, WNr	Japan JIS	France AFNOR	England BS	China GB	Russia GOST
38	C10	C10E (1.1121)		Ck10 Ck15		XC10 XC12	045M10 CS12		08 10
		C10R (1.1207)		Ck10		XC10			
39	C105U	C105U (1.1545)	W5	C105W1	SK3	C105E2U	BW1B	T10A	U10A
40	C15E4	C15E (1.1141)	Gr.1015 Gr.1016	1.1141 C15 Ck15	S15C	C18RR XC12 XC15	040A15 080M15 CS17	15	15
41	C15M2	C10E (1.1121)		Ck10 Ck15		XC10 XC12	045M10 CS12		08 10
		C15R (1.1140)		Ck15 Cm15		XC12			
42	C16E4	C16E (1.1148)				XC18	080M15		
43	C25	C25 (1.0406)		C25					25
		C22 (1.0402)	SAE1020	1.0402 C22	S20C S22C		070M20	20	20
44	C25E4	C25E (1.1158)		Ck25	S25C	XC25	070M26		25
45	C30	C30 (1.0528)	SAE1030	1.0528 C30 Ck30	S30C	AF50C30 XC32	080M32 En5	30	30
46	C30E4	C30E (1.1178)		Ck30	S30C	XC32	080M30 CS30		30
		C30 (1.0528)	SAE1030	1.0528 C30 Ck30	S30C	AF50C30 XC32	080M32 En5	30	30
47	C35	C35 (1.0501)	1035 Gr.1035	1.0501 C35	S35C	AF55C35 C35	070M36 40HS	35	35 40
48	C35E4	C35E (1.1181)	1035	Ck35	S35C	XC38 XC38H1	080M36 CFS6	35	35
49	C35M2	C35R (1.1180)	1035	C35 Cm35		XC38H1u	080M36		
50	C40	C40 (1.0511)	1038 1040	1.0511 C40 Ck40	S40C	AF60C40 AF60C45 XC42HI	070M40 080M40 En8	40	40
51	C40E4	C40E (1.1186)	1040	Ck40	S40C	XC42H1	080M40 CS40		40
		C40 (1.0511)	1038 1040	1.0511 C40 Ck40	S40C	AF60C40 AF60C45 XC42HI	070M40 080M40 En8	40	40
52	C40M2	C40R (1.1189)	1040	Cm40		XC42H1u			
53	C45	C45 (1.0503)	1042 1045 Gr.1043	C45	S45C	AF65C45 C45	070M46 50HS	45	45
54	C45E4	C45E (1.1191)	1045	Ck45	S45C	XC45 XC48H1	080M46 CFS8	45 45H	45
55	C45M2	C45R (1.1201)	1045	Cm45		XC48H1u			
56	C50	C50 (1.0540)	1049 1050	C50 Ck50	S50C	XC48H1	070M50 080M50	50	50
57	C50E4	C50E (1.1206)	1050	Ck50	S50C	XC50	080M50 CS50		50
58	C50M2	C50R (1.1241)	1050	Cm50					
59	C55	C55 (1.0535)	1055	C55	S55C	AF70C55 C54	070M55 50 En9	55	50 55
60	C55E4	C55E (1.1203)	1055	Ck55	S55C	XC54 XC55H1	070M55		55
61	C55M2	C55R (1.1209)		Cm55		XC55H1u			
62	C60	C60 (1.0601)	1060	C60	S58C		070M60	60	60 60G
63	C60E4	C60E (1.1221)		Ck60	S58C	XC60	070M60 CS60	60	60 60G
64	C60M2	C60R (1.1223)		Cm60					

#	International ISO	EU EN	USA AISI, ASTM, UNS	Germany DIN, WNr	Japan JIS	France AFNOR	England BS	China GB	Russia GOST
65	C70U	C70U (1.1520)	W1-7	1.1620 C70W2	SK6 SK7	C70E2U		T7	U7
66	Cr01	DC01 (1.0330)	SAE1008 SAE1010	FeP01 St12	SPCC	C F12 FeP01	CR4 FeP01	08 08F	08kp 08ps
67	Cr04	DC04 (1.0338)	A619 DDS	1.0338 RRSt14 St14	SPCE	ES	1CR 1CS 1HR 1HS CR1		05kp 08kp 08YU
68	CR22	DC01 (1.0330)	SAE1008 SAE1010	FeP01 St12	SPCC	C F12 FeP01	CR4 FeP01	08 08F	08kp 08ps
69	CR24	DC04 (1.0338)	A619 DDS	1.0338 RRSt14 St14	SPCE	ES	1CR 1CS 1HR 1HS CR1		05kp 08kp 08YU
70	E235B	S235JR (1.0038(dubl))	1015 A283C GradeC GradeD SSGrade33	RSt37-2 St37-2	SM400A SS400	E24-2	40A 40B	Q235A Q235B Q235D	St2ps St2sp St3ps St3sp
71	E235C	S235JO (1.0114)	A284C A284D	St37-3U	SM400B	E24-3	40C	Q235C	St3ps St3sp
72	E275B	S275JR (1.0044)	A283D A529 Gr.D	RSt42-2 St 44-2	SS400	E28-2	161-430 43A 43B	Q225A Q275Z	St4ps St4sp
73	E275C	S275JO (1.0143)	A578Gr.70	St44-3 St44-3U		E28-3	43C	Q275	St4ps St4sp
74	E355	P355N (1.0562)	A537CL1	StE355	SM490B	A510AP E355R	223Gr.490 50DD	20	15GF
75	E355C	S355JO (1.0553)	A441 A63	St52-3U	SS490B	E36-3	50C	16Mn	
		S355JR (1.0045)	A572 A678Gr.A SSGrade50	St52-3	SM490A SS490	E36-2	50B	Q345B Q345C	
76	E355E	P355NL1 (1.0566)	A737Gr.B	TStE355		A510AP A510FP1 A530AP E355FP	224Gr.490 50EE		
77	E420	S420N (1.8902)	A255Gr.D A633E	StE420	SM490A SM490C	E420R		Q420D	16G2AF
78	E460	S460N (1.8901)		StE460	SM520B	E460R	55C	Q460D	18G2AF 18G2AFps
		S460QL (1.8906)		TStE460V		E460T E460TFP S460T	55F		
79	E500	S500QL (1.8909)		TStE500V		E500T E500TFP S500T			
80	E550	S550QL (1.8926)		TStE550V		E550T E550TFP S550T			
81	E620	S620QL (1.8927)		TStE620V		E620T E620TFP S620T			
82	E690	S690QL (1.8928)	A709-100	TStE690V		E690T E690TFP S690T			
83	F26	16Mo3 (1.5415)	A204Gr.A A204Gr.B	15Mo3 16Mo3	STBA12	15D3	1503-243B 240 243		
84	F32	13CrMo4-5 (1.7335)	A387Gr.12 Gr.P12	13CrMo4-4	SFVAF12	15CD2.05 15CD4-05 15CD4-5	620 620-440 620Gr.27	12CrMo	12KHM 15KHM



#	International ISO	EU EN	USA AISI, ASTM, UNS	Germany DIN, WNr	Japan JIS	France AFNOR	England BS	China GB	Russia GOST
85	F34	10CrMo9-10 (1.7380)	A387Gr.22 Gr.P22	10CrMo9-10	SCMV4	10CD9-10 12CD9-10	622 622Gr.31	12CrMo	10KH2M
86	F5	P265GH (1.0425)	A414E A516Gr.60 Gr.A	1.0425 H11 St45.8	SG295	A42AP A42CP A42F	151-400 161-430 161Gr.400 164Gr.400 244Gr.400		16K 20K
87	F7	P265GH (1.0425)	A414E A516Gr.60 Gr.A	1.0425 H11 St45.8	SG295	A42AP A42CP A42F	151-400 161-430 161Gr.400 164Gr.400 244Gr.400		16K 20K
88	Fe310	S185 (1.0035)	A283A A283B Gr.A	S185 St33	SS330	A33	15HR 15HS S185	Q195	St0 St1ps St1sp
89	Fe355W	S355J0W (1.8959)	A242Gr.1 A588 A709-50W		SMA50AW	E36WB3	WR50B		17G1S
90	Fe355W-1A	S355J0WP (1.8945)	Gr.1	9CrNiCuP324	SPA-H	E36WA3	WR50A WR50B WR50C	09CuPCrNi-A	
91	Fe360B	S235JR (1.0038(dubl))	1015 A283C GradeC GradeD SSGrade33	RSt37-2 St37-2	SM400A SS400	E24-2	40A 40B	Q235A Q235B Q235D	St2ps St2sp St3ps St3sp
			Gr.C	1.0028 1.0036 St34-2 USt37-2	SS330 STKM12A	A34-2 S235JRG1	CEW2BK Fe360B	A3 Q235	16D 18kp St3kp
		S235JRG2 (1.0038)	Gr.36	RSt37-2 S235JRG2	SS330	E24-2NE	40B	Q235C	St3ps St3sp
92	Fe360D	S235J2(+N) (1.0116(dubl))	A284D	St37-3N	SM400C	E24-4	40D		St3ps St3sp
93	Fe430D	S275J2(+N) (1.0144)	A572 A633Gr.A	St44-3N		E28-4	43D	Q255	St4kp St4ps
94	Fe510B	S355JR (1.0045)	A572 A678Gr.A SSGrade50	St52-3	SM490A SS490	E36-2	50B	Q345B Q345C	
95	Fe510C	S355J0 (1.0553)	A441 A633	St52-3U	SS490B	E36-3	50C	16Mn	
96	Fe510D	S355J2(+N) (1.0570(dubl))	1024	1.0570 St52-3 St52-3N	SM490 SM490C SS490C	E36-3	50D	16Mn	17G1S 17GS S345
97	Fe590	E355 (1.0580)	Gr.65	1.0060 E355 St52 St52-3		E335 ES355 TS-47a TU526	CEW5 CFS5 E335 ERW5NKM ERW5NZF		St6sp
98	Fe690	E360 (1.0070)		1.0070 St70-2		A70 A70-2	E360	Q390C	S375
99	FeE355	S355MC (1.0976)	Gr.50	QStE360TM	SPFH540	E355D E390D	46F35 46F40		
100	FeE420	S420MC (1.0980)	Gr.60	QStE420TM	SPFH590	E420D	HR50F45		
101	FeE490	S500MC (1.0984)	Gr.70	E490D QStE500TM		E490D			
102	FeE560	S550MC (1.0986)	Gr.80	QStE550TM		E560D	60F45 60F55		
103	FeE690	E335 (1.0060)		St60-2		A60-2		Q345C	St5ps St5sp St6ps St6sp
		E360 (1.0070)		1.0070 St70-2		A70 A70-2	E360	Q390C	S375

#	International ISO	EU EN	USA AISI, ASTM, UNS	Germany DIN, WNr	Japan JIS	France AFNOR	England BS	China GB	Russia GOST
104	H16	X8CrNi25-21 (1.4845)	310S S31008	X8CrNi25-21	SUS310S	Z8CN25-20	310S16 310S24 310S31	1Cr25Ni20Si2	10KH23N18 20KH23N18
105	H17	X12NiCrSi35-16 (1.4864)	330	X12NiCrSi36-16	SUH330	Z12NCS37-18		1Cr16Ni35	
106	HR2	DD11 (1.0332)	A621CQ CS	StW22	SPHD	1C	HR3		15kp
107	HR4	DD13 (1.0335)	A622DQ DS	StW24	SPHE SPHE-AK	3C	HR1		08kp
108	HS18-0-1	HS18-0-1 (1.3355)	T1	HS18-0-1	SKH SKH2	Z80WCV18-04-01	BT1	W18Cr4V	R18
109	HS6-5-2	HS6-5-2 (1.3339)	M2	HS6-5-2	SKH51	Z85WDCV06-05-04-02	BM2	W6Mo5Cr4V2	R6M5
110	HS6-5-2-5	HS6-5-2-5 (1.3243)		S6-5-2-5	SKH55	Z85WDCV06-05-04-02	BM35	W6Mo5Cr4V2Co5	R6M5K5
111	P1024Z	S-Fe-175 (Nonumber)							
112	P1025Z	S-Fe-170 (Nonumber)							
113	P11	P295GH (1.0481)	A516Gr.65 X46	1.0436 17Mn4 Ast45	SG365 SPV315 SPV32 SPV32	A48AP A48CP A48FP	224-460B 224Gr.460 224Gr.490 430LT		14G2 18K
114	P26	16Mo3 (1.5415)	A204Gr.A A204Gr.B	15Mo3 16Mo3	STBA12	15D3	1503-243B 240 243		
115	P3	P235GH (1.0345)	A285 A285Gr.C	1.0345 Ast35 HI StE255	SB410 SGV410 SPV235 SPV24	A37AP A37CP	141-360 161Gr.360	20	12k
116	P32	13CrMo4-5 (1.7335)	A387Gr.12 Gr.P12	13CrMo4-4	SFVAF12	15CD2.05 15CD4-05 15CD4-5	620 620-440 620Gr.27	12CrMo	12KHM 15KHM
117	P34	10CrMo9-10 (1.7380)	A387Gr.22 Gr.P22	10CrMo9-10	SCMV4	10CD9-10 12CD9-10	622 622Gr.31	12CrMo	10KH2M
118	TS26	16Mo3 (1.5415)	A204Gr.A A204Gr.B	15Mo3 16Mo3	STBA12	15D3	1503-243B 240 243		
119	TS34	10CrMo9-10 (1.7380)	A387Gr.22 Gr.P22	10CrMo9-10	SCMV4	10CD9-10 12CD9-10	622 622Gr.31	12CrMo	10KH2M
120	Type19	X2CrNiMo17-12-2 (1.4404)	316L	X2CrNiMo17-13-2	SUS316 SUS316L	Z2CND17-12 Z3CND17-11-02 Z3CND18-12-02	316S11	00Cr17Ni14Mo2 0Cr18Ni12Mo2Ti	
121	Type19a	X2CrNiMo18-14-3 (1.4435)	316L TP316L	X2CrNiMo18-14-3	SUS316L	Z3CND17-12-03 Z3CND18-14-03	316S13 316S14	00Cr17Ni14Mo2	
122	Type20a	X3CrNiMo17-13-3 (1.4436)	316		SUS316	Z7CND18-12-03 Z7CND18-12-3	316S31 316S33	0Cr17Ni12Mo2	
123	Type9	X53CrMnNiN21-9 (1.4871)	EV12	X53CrMnNiN21-9	SUH35	Z52CMN21-09	349S54	5Cr21Mn9Ni4N	55KH20G9AN4
124	X100CrMoV5	X100CrMoV5 (1.2363)	A2	X100CrMoV5-1	SKD12	Z100CDV5	BA2	Cr5Mo1V	9KH5VF
125	X15CrN26	X18CrN28 (1.4749)	446 S44600						
126	X210Cr12	X210Cr12 (1.2080)		X210Cr12	SKD1	Z200C12	BD3	Cr12	KH12
127	X210CrW12	X210CrW12 (1.2436)		X210CrW12		X210CrW12-1			
128	X30WCrV9-3	X30WCrV9-3 (1.2581)	H21	X30WCrV9-3	SKD5	Z30WCV9	BH21	3Cr2W8V	3KH2V8F
129	X37CrMoV5-1	X37CrMoV5-1 (1.2343)	H11	X38CrMoV5-1	SKD6	Z38CDV5	BH11	4Cr5MoSiV	4KH5MFS
130	X7CrNi18-9	X6CrNi18-10 (1.4948)	304H S30409		SUS304H	Z6CN18-09			08KH18N10
131	X7CrNiAl17-7	X7CrNiAl17-7 (1.4568)	631			Z9CNA17-07	301S81		09KH17N7YU
132	X7CrNiSiN21-11	X9CrNiSiN21-11-2 (1.4835)	S30815						
133	X7CrNiTi18-10	X8CrNiTi18-10 (1.4878)	321H S32109		SUS321H	Z6CNT18-10	321S12 321S51		12KH18N10T
134	X8NiCrAlTi32-21	X10NiCrAlTi32-21 (1.4876)	800 N08800						
135	X9CrNi18-8	X10CrNi18-8 (1.4310)	301	X12CrNi17-7	SUS301	Z11CN18-08 Z12CN18-09	301S21 302S26		

---

# NOTE

# Zhejiang Huaguang Seiko Manufacture Co., Ltd.

---

Headquarter 〒325300  
Juyu Industry Park,  
Wencheng County,  
Wenzhou,  
Zhejiang Province,  
China

---

Shanghai 〒201107  
Longhu Hongqiao Tianjie,  
Shenbinnan Road 998,  
Minhang District,  
Shanghai,  
China

---

**Contact**     **Shoa Yu**  
*Deputy Chief Executive Officer*

China Mobile +81 (0)50 5806 0688

Japan Mobile +86 178 5873 3734

Email            shoa.yu@huaguangseiko.com

WeChat



Homepage



---

© 2021 Huaguang Seiko All rights reserved.

Huaguang Seiko refers to the Zhejiang Huaguang Seiko Manufacture Co., Ltd. and/or Zhejiang Huaguang Precision Manufacturing Co., Ltd. in China. Both of the names are the English translation of “浙江华广精工制造有限公司”.

Please see [www.huaguangseiko.com](http://www.huaguangseiko.com) for further details.

